

# MITSUBISHI

## 三菱工業用ミシン部品カタログ

## Industrial Sewing Machine Parts Catalog

Model PLK-E1008H

PLK-E2008H

	目次	CONTENTS	Page
A	本体構成	Construction .....	1
B	本体関係	Arm bed & it's accessories .....	2
C	縫い機構(1)	Sewing mechanism (1) .....	4
D	縫い機構(2)	Sewing mechanism (2) .....	6
E	中押え機構	Presser bar lifting mechanism .....	8
F	上糸切り機構(1)	Upper thread trimming mechanism (1) .....	10
G	上糸切り機構(2)	Upper thread trimming mechanism (2) .....	12
H	下糸切り機構	Lower thread trimming mechanism .....	14
J	糸調子機構	Thread guide mechanism .....	16
K	糸巻き装置機構	Bobbin winder mechanism .....	18
L	X-Yテーブル機構	X-Y table mechanism .....	20
M	外押え機構	Work holder mechanism .....	22
N	配線配管機構(1)	Cable and air components (1) .....	24
P	配線配管機構(2)	Cable and air components (2) .....	26
Q	付属品(1)	Accessories (1) .....	28
R	付属品(2)	Accessories (2) .....	30
	索引	Index .....	32

## 部品コードの採番形式

### MITSUBISHI SPARE PARTS No. Designation system

#### 1. 部品コードについて CONCERNING PARTS CODE.

部品をご注文される場合は、部品コードをお知らせください。

Please inform the part number, when these parts are ordered.

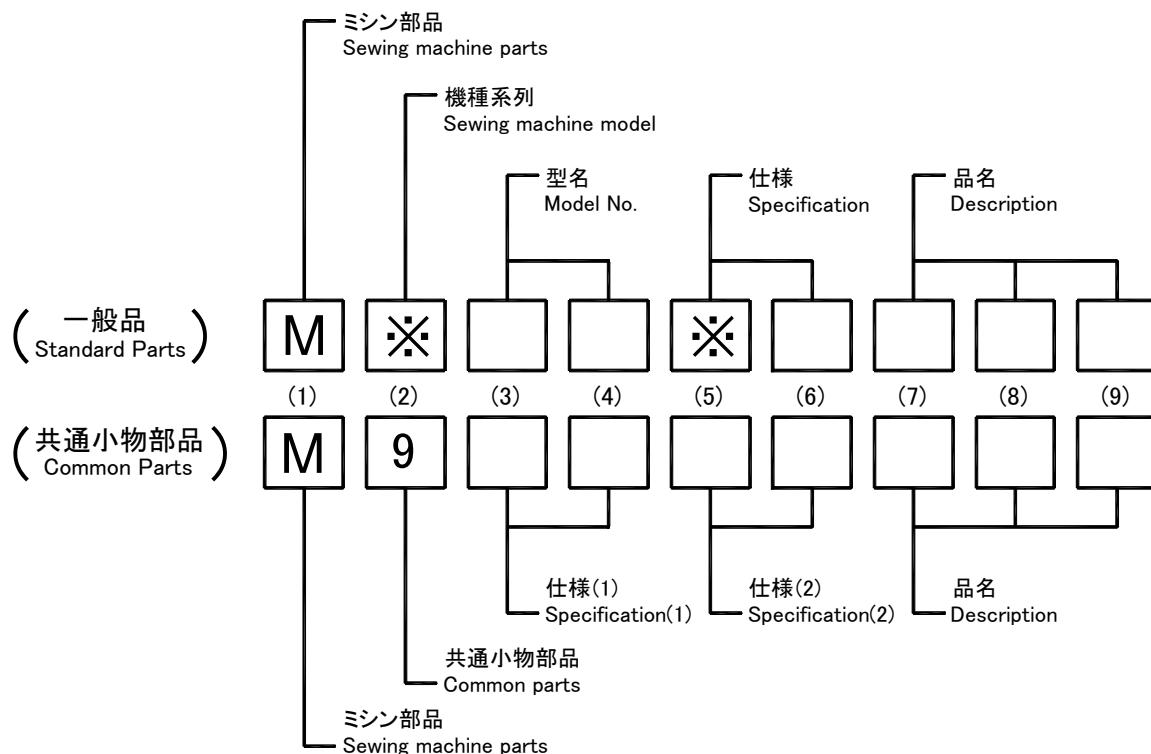

[ 例 ]  
Example

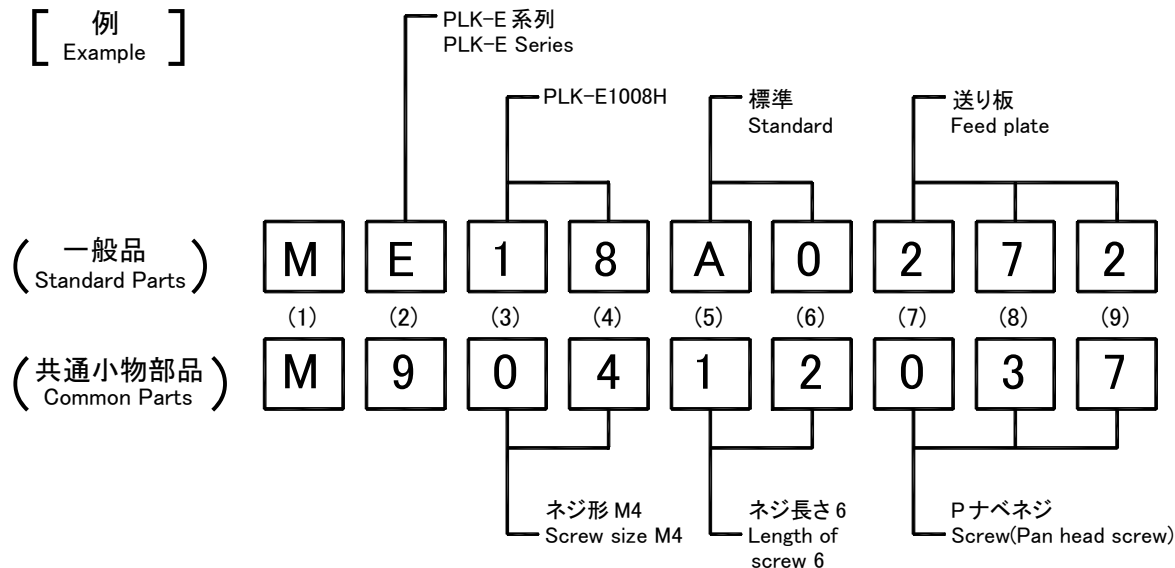

#### 2. 変更マークについて CONCERNING MODIFICATION MARK.

変更マーク欄に\*記号のある部品は、形状、寸法などの変更履歴がありますので、ご注文の際にはご使用の製品の製造番号と合わせてご覧ください。

The parts marked with \* in the modification column has been changed the shape or size etc. So when these modified parts are ordered please inform the serial number of the sewing machine.

注: 一般品についての機種型名は、その部品が最初に使用された機種型名を示します。従って長期にわたる場合は、機種の変更が行われるため、当初の機種以外の機種で使用されている場合があります。

Sewing machine Models, of Standard Parts are Indicated model of these parts are registered firstly. Parts are used for not only the indicated model, but also another models, in reason of New development, improvement after.

**A** 全体構成  
CONSTRUCTION

---

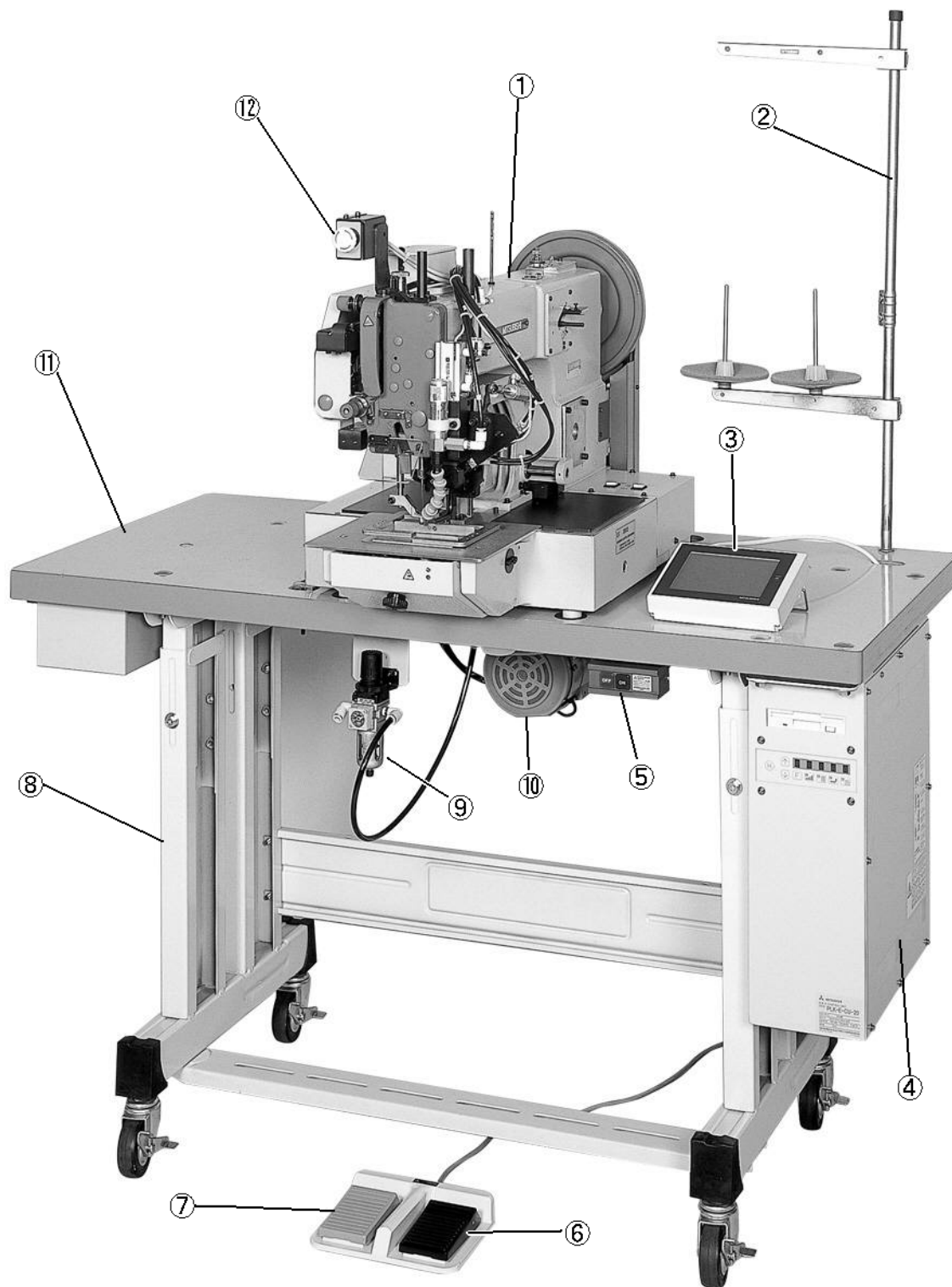

- (1)Sewing machine head (2)Thread stand (3)Teaching panel (4)Control Unit  
(5)Power switch (6)Work holder foot switch (7)Start foot switch (8)Table  
(9)Air regulation gauge (10)Limi-servo motor (11)Wooden table (12)Emergency stop switch

**B** 本体関係  
 ARM BED & IT'S ACCESSORIES

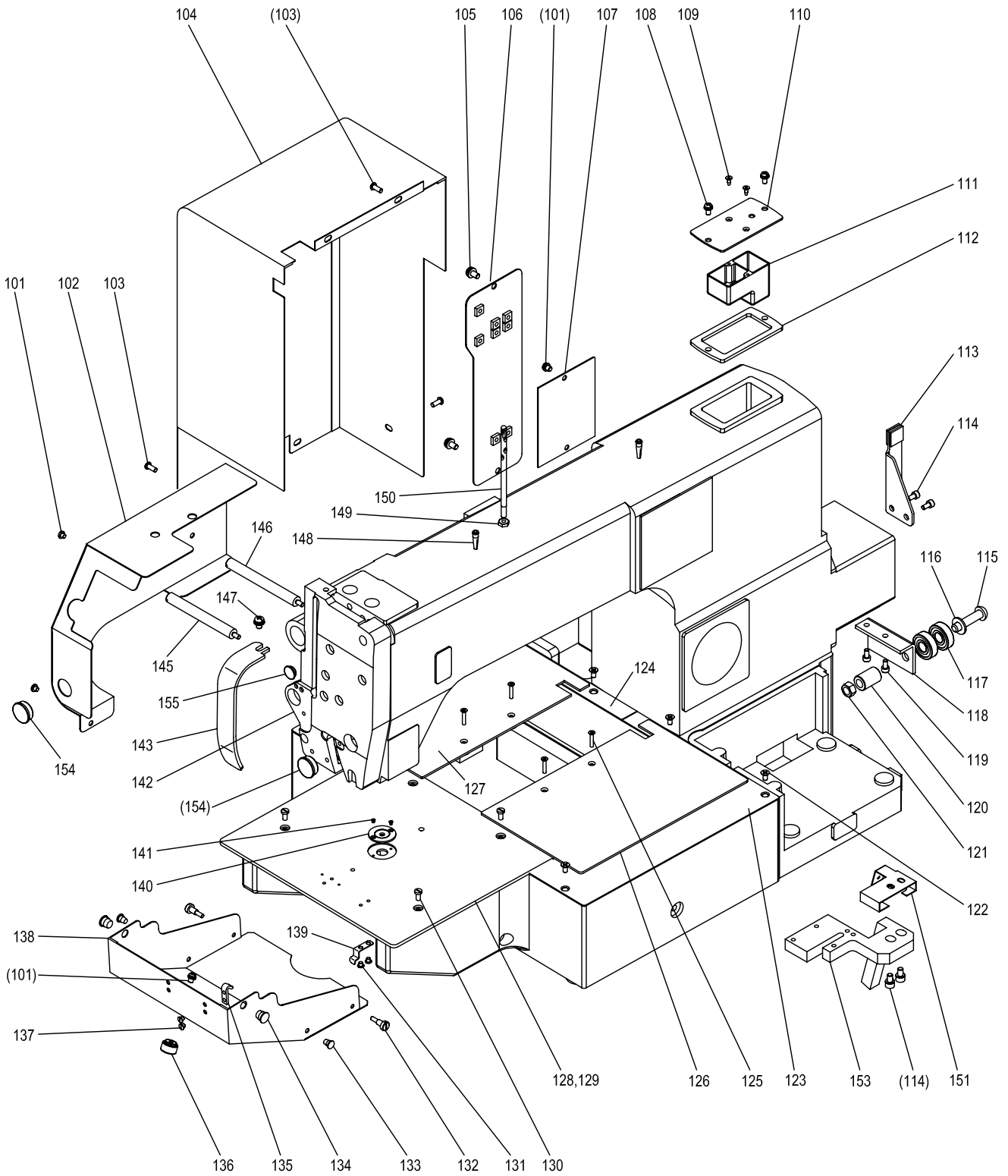

[B] 本体関係  
ARM BED & IT'S ACCESSORIES

Fig no.	変更 Mod.	部品コード Parts no.	品名	Description	数量	
					Amt. Req. E1008H	2008H
B 101		M91058004	SW-PWフライナイナベネジ M4X6	Screw M4X6	4	4
B 102		MB18A9339	ヒタリソクメンカバー	Link cover	1	1
B 103		M91071004	SW-MWフライナイナベネジ M4X8	Screw M4X8	5	5
B 104		MB18E2339	モータカバー	Motor cover	1	1
B 105		M91067004	SW-PWフライネジ M5X10	Screw M5X10	2	2
B 106		MB18E0742	ヨコフタ	Arm side cover	1	1
B 107		MB18A1742	フタ	Cover	1	1
B 108	C	M91059004	SW-PWフライナイナベネジ M4X12	Screw M4X12	2	2
B 109		M90357037	Pサラタッピンネジ 3X8	Screw TAP-V 3X8	2	2
B 110		MB18A0132	アブラフタ	Oil reservoir cover	1	1
B 111		MB18E0139	オイルタンク	Oil reservoir	1	1
B 112		MB18A2476	スペーサ	Spacer	1	1
B 113		MB18E0802	マワリメ	Holder	1	1
B 114	C	M95003017	セフティソケット M5X8	Bolt M5X8	4	4
B 115		M91803022	ロッカクアナツキホルタンホルト M8X40	Bolt M8X40	1	1
B 116		M90823050	ミガキサガネ 8	Washer 8	2	2
B 117		MS10A1456	ジクウケ	Ball bearing	2	2
B 118		MB18B1601	トリツケイタ	Guide plate	1	1
B 119		M94002017	セフティソケット M4X8	Bolt M4X8	2	2
B 120		MB60A0750	ブッシュ	Bushing	1	1
B 121		M92075045	ナット M8	Nut M8	1	1
B 122	C	M94005037	Pサラネジ M4X8	Screw M4X8	6	6
B 123		MB18A0339	X-Yカバー-ミキ	X-Y cover (R)	1	*
B 123	B	ME28A0339	X-Yカバー-ミキ	X-Y cover (R)	*	1
B 124		MB18A1339	X-Yカバー-ヒタリ	X-Y cover (L)	1	*
B 124	B	ME28A1339	X-Yカバー-ヒタリ	X-Y cover (L)	*	1
B 125	C	M90361037	Pサラネジ M3X16	Screw M3X16	4	4
B 126		MB18E1339	Xカバー-イタクミタテミキ	X cover plate (R)	1	*
B 126	B	ME28E0339	Xカバー-イタクミタテミキ	X cover plate (R)	*	1
B 127		MB18E0339	Xカバー-イタクミタテヒタリ	X cover plate (L)	1	*
B 127	B	ME28E1339	Xカバー-イタクミタテヒタリ	X cover plate (L)	*	1
B 128		MB18A0470	スベリイタ	Slide plate	1	*
B 128	B	ME28A0470	スベリイタ	Slide plate	*	1
B 129		MB18A0797	ホコフィルム	Protection film	2	*
B 129	B	ME28A0797	ホコフィルム	Protection film	*	3
B 130		M90990002	ヒラネジ M4X8	Screw M4X8	4	4
B 131		M90906003	マルヒラネジ 9/64(40)X3.2	Screw 9/64(40)X3.2	2	2
B 132		M94001030	トクシュネジ M5	Special screw M5	2	2
B 133		M90573080	ゴムセン φ5.7	Rubber plug φ5.7	2	2
B 134		M90883080	ゴムセン φ8.8	Rubber plug φ8.8	2	2
B 135		MS01A0361	カケガネ	Latch	1	1
B 136		MB61A0650	ナールトノブ KN-5	Knurled knobs KN-5	1	1
B 137		M90906003	マルヒラネジ 9/64(40)X3.2	Screw 9/64(40)X3.2	2	2
B 138		MB18E4339	シリンダカバー	Cylinder cover	1	1
B 139		MS10A0192	イタハネ	Leaf spring	1	1
B 140		MB18A0101	ハリイタ	Needle plate	1	1
B 141		M90605010	サラネジ 3/32(56)X4	Screw 3/32(56)X4	2	2
B 142		MB18A0830	メンイタ	Face plate	1	1
B 143		MB18A0584	テンビンカバー	Thread take-up cover	1	1
B 145	C	M91404017	スタッドホルト M4X75	Stud bolt M4X75	1	1
B 146	C	M91405017	スタッドホルト M4X80	Stud bolt M4X80	1	1
B 147		M91330004	SW-PWフライナイナベネジ M5X8	Screw M5X8	1	1
B 148		MB18A0251	ウワイトオサエ オイルカップ	Top thread holder oil cup	2	2
B 149		M91254045	ロッカクナット 3/16(32)	Nut 9/32(32)	2	2
B 150		MB18A0157	イトアンナイホウ	Thread guide bar	1	1
B 151		ME18A0780	フェルトホルダ	Felt holder	1	1
B 153		ME18A0740	フェルト	Felt	1	1
B 154	C	M91910080	ゴムセン φ19	Rubber plug φ19	5	5
B 155	C	M91183080	ゴムセン φ10.8	Rubber plug φ10.8	5	5

**C** 縫い機構(1)  
SEWING MECHANISM(1)

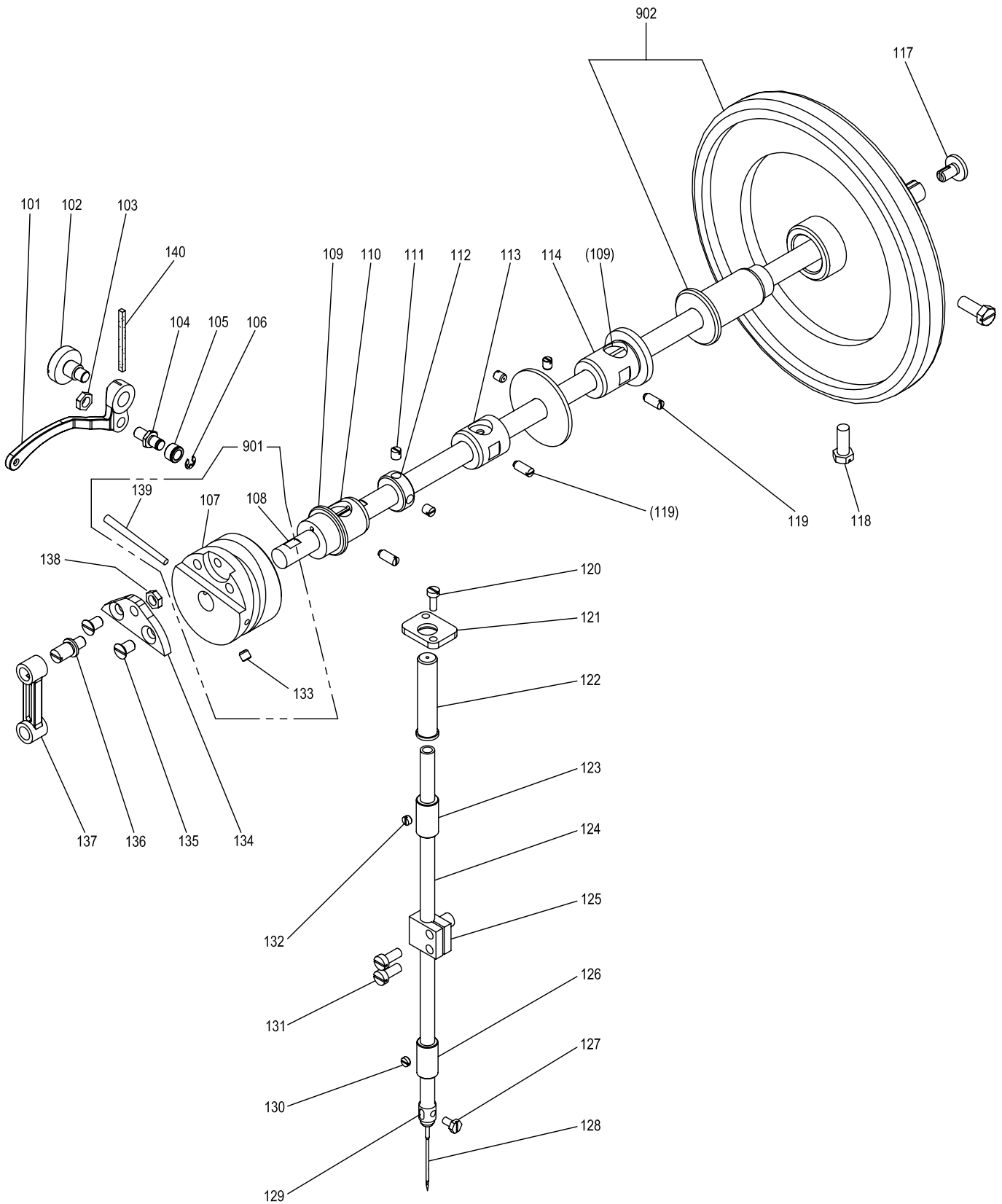

[ご注意] 上軸(108)を単品でご注文された場合、上軸にはテーパピン用の穴は加工されておりません。  
[Note] When ordering the arm shaft (108) as a unit, taper hole on the arm shaft is not processed.

[C]縫い機構(1)  
SEWING MECHANISM (1)

Fig no.	変更 Mod.	部品コード Parts no.	品 名	Description	数量	
					Amt. Req. E1008H	2008H
C 101		MB18A0582	テンピン	Take-up lever	1	1
C 102		M92004015	ダ`ネジ 5/16(24)X16.5	Screw 5/16(24)X16.5	1	1
C 103		M91807045	ロックナット 9/32(28)	Nut 9/32(28)	1	1
C 104		MB18A0412	テンピンロシク	Thread take-up roller stud	1	1
C 105		MB18A2411	オクリハンカンウデコロ	Roller	1	1
C 105		MB18A0411	オクリハンカンウデコロ (Lサイズ)	Roller (L-size)	*	*
C 105		MB18A1411	オクリハンカンウデコロ (LLサイズ)	Roller (LL-size)	*	*
C 106		M90804065	Eカ`外メワ	E-type retaining ring	1	1
C 107		MB18A0581	テンピンカム	Thread take-up cam	1	1
C 108	C	ME18A0230	ウワジク	Arm shaft	1	1
C 109		MB18A0231	ウワジクマエメタル	Hook shaft bushing	1	1
C 110		MB18A0740	ウワジクメタルフェルト	Felt	3	3
C 111		M91635001	トメネジ 1/4(40)X6	Screw 1/4(40)X6	2	2
C 112		MB18A0456	ウワジクスラストウケ	Arm shaft thrust supporter	1	1
C 113		MB18A0234	ウワジクナカメタル	Arm shaft bushing (Middle)	1	1
C 114		MB18A0233	ウワジクウシロメタル	Arm shaft bushing (Right)	1	1
C 117		M92055003	ハス`ミグルマオシアケ`ネジ 5/16(24)	Screw 5/16(24)	1	1
C 118		M92005022	ロックホルト 5/16(24)X21	Bolt 5/16(24)X21	2	2
C 119		M91523001	トメネジ 15/64(28)X15	Screw 15/64(28)X15	3	3
C 120		M91140002	ヒラネジ 11/64(40)X12	Screw 11/64(40)X12	2	2
C 121		MB18A4339	ハリホ`ウカハ`プレート	Needle bar cover plate	1	1
C 122		MB18A7339	オサエホ`ウカハ`	Presser bar cover	1	1
C 123		MB18A0663	ハリホ`ウウワメタル	Bushing for presser bar upper	1	1
C 124		MB18A0660	ハリホ`ウ`	Needle bar	1	1
C 125		MB18A0665	ハリホ`ウダ`キ	Needle bar holder	1	1
C 126		MB18A0664	ハリホ`ウシタメタル	Needle bar lower bushing	1	1
C 127	C	M91107022	ミゾ`ツキホルト 11/64(40)X8.5	Bolt 11/64(40)X8.5	1	1
C 128		MB18A0128	ハリ`	Needle	1	1
C 129		MB18A3180	ハリホ`ウイトカケ	Needle bar thread guide	1	1
C 130		M91633001	トメネジ 1/4(40)X2.5	Screw 1/4(40)X2.5	1	1
C 131		M91524002	ヒラネジ 15/64(28)X14	Screw 15/64(28)X14	2	2
C 132		M91524001	トメネジ 15/64(28)X3.4	Screw 15/64(28)X3.4	1	1
C 133		M91634001	ロックア`ナツキトメネジ 1/4(40)X6	Screw 1/4(40)X6	2	2
C 134		MB18A0662	ハリホ`ウクラ`クサ`	Needle bar crank adapter	1	1
C 135		M91600010	サラネジ 9/32(28)X11	Screw 9/32(28)X11	2	2
C 136		MB18A6454	ハリホ`ウクラ`クロツ`シク`	Needle bar crank rod shaft	1	1
C 137		MB18A0661	ハリホ`ウクラ`クロツ`	Needle bar crank rod	1	1
C 138		M91807045	ロックナット 9/32(28)	Nut 9/32(28)	1	1
C 139		MB18A7454	テーパ`ピン	Taper pin	1	1
C 140	C	MS07A0740	フェルト	Felt	1	1
C 901	C	ME18E1230	ウワジ`クミタテ`	Arm shaft assy.	1	1
C 902		MB18E0682	ハス`ミグルマ`クミタテ`	Pulley assy.	1	1

# D 縫い機構(2) SEWING MECHANISM(2)

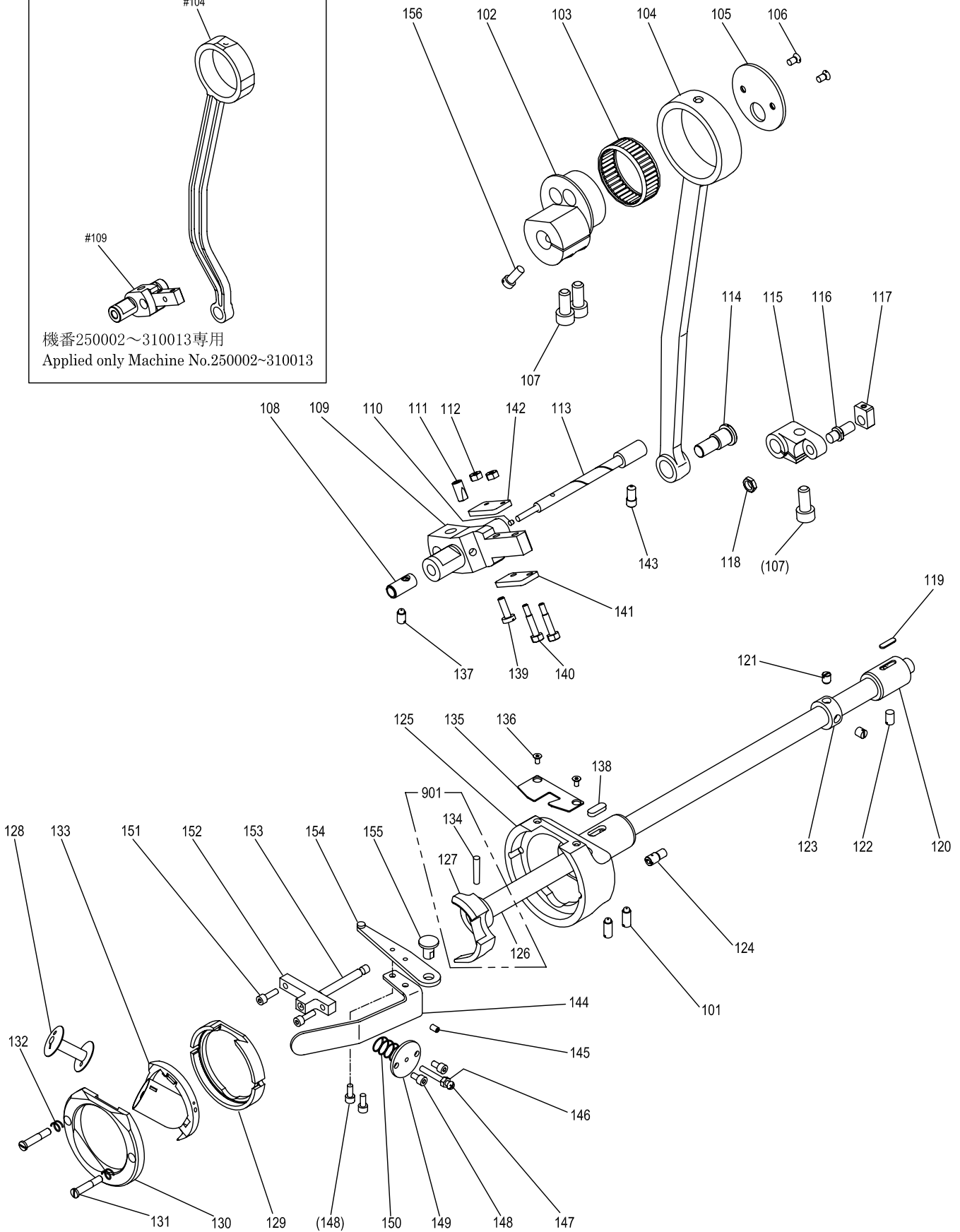
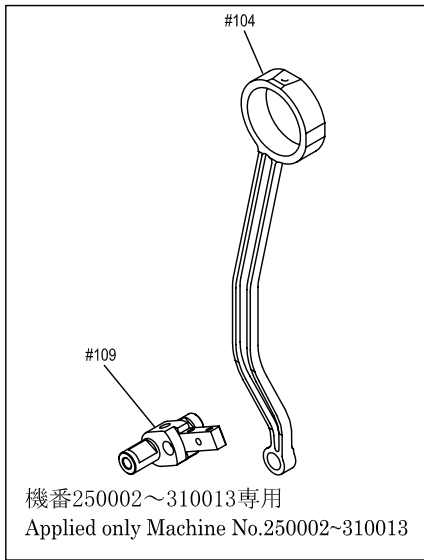

[ご注意] 下軸(126)を単品でご注文された場合、下軸にはテーパピン用の穴は加工されておりません。

[Note] When ordering the bottom shaft (126) as a unit, taper hole on the bottom shaft is not processed.

[D]縫い機構(2)

SEWING MECHANISM (2)

Fig no.	変更 Mod.	部品コード Parts no.	品名	Description	数量	
					Amt. 180H	Req. 2008H
D 101	C	M91523001	トメネジ 15/64(28)X15	Screw 15/64(28)X15	2	2
D 102		MB18A0350	タテロッドヘンシンカム	Vertical rod eccentric cam	1	1
D 103		MB18A0914	ゲージ & ローラ	Gauge & roller	1	1
D #104		MB18A1955	タテロッド	Vertical rod	1	1
D 104		ME18A0955	タテロッド	Vertical rod	1	1
D 105		MB18A0327	タテロッドヘンシンカムソクパン	Side plate	1	1
D 106		M91119011	マルサラネジ 11/64(40)X6.8	Screw 11/64(40)X6.8	2	2
D 107		M98014021	ロッククアナツキホルト M8X18	Bolt M8X18	3	3
D 108		MB18A1833	オオフリコジクマエメタル	Large pendulum hook shaft bushing	1	1
D #109		MB18A0756	オオフリコ	Large pendulum	1	1
D 109		ME18A0756	オオフリコ	Large pendulum	1	1
D 110		M90301080	トメセン φ3.2(φ2.9)X3	Plug	1	1
D 111		MB18A0688	トメパイプ	Brock	1	1
D 112		M91111045	ロッククナット 11/64(40)	Nut 11/64(40)	2	2
D 113		MB18A0454	オオフリコジク	Large pendulum shaft	1	1
D 114		MB18A0955	タテロッドレンケツジク	Vertical rod connecting shaft	1	1
D 115		MB18A0757	コフリコ	Small pendulum	1	1
D 116		MB18A1412	コフリココロジク	Pendulum roller stud	1	1
D 117		MB18A0325	コフリコカタマ	Small pendulum square block	1	1
D 118		M91808045	ロッククナット 9/32(28)	Nut 9/32(28)	1	1
D 119		MB18A3740	シタジクメタルフェルト	Lower shaft bushing felt	1	1
D 120		MB18A0452	シタジクウシロメタル	Lower shaft bushing right	1	1
D 121		M91635001	トメネジ 1/4(40)X6	Screw 1/4(40)X6	2	2
D 122		M91525001	トメネジ 15/64(28)X7	Screw 15/64(28)X7	1	1
D 123		MB18A0833	スラストウケ	Thrust supporter	1	1
D 124		MB18A9454	ジョウゲメカネピン	Top feed lifting pin	1	1
D 125		MB18A0451	シタジクマエメタル	Lower shaft bushing left	1	1
D 126		MB18A0450	シタジク	Hook shaft	1	1
D 127		MB18A0611	トンビ	Driver	1	1
D 128		MB18A0123	ホピン	Bobbin	1	1
D 129		MB18A0121	オオカマ	Caldron	1	1
D 130		MB18A0742	オオカマフタ	Caldron cover	1	1
D 131		M91209001	オオカマフタトメネジ 3/16(28)	Screw 3/16(28)	2	2
D 132		MB18A0572	オオカマバネ	Caldron spring	2	2
D 133		MB18A0120	カマ	Inner hook	1	1
D 134		MB18A8454	テーパピン	Taper pin	1	1
D 135		MB18A0154	シタイトアンナイタ	Lower thread guide plate	1	1
D 136		M93015021	アナツキサラホルト (M3)	Bolt M3	2	2
D 137		M91526001	トメネジ 15/64(28)X10.5	Screw 15/64(28)X10.5	1	1
D 138		MB18A2740	ジョウゲオクリロッドフェルト	Feed connecting felt	1	1
D 139		M91253003	マルヒラネジ 3/16(32)X15	Screw 3/16(32)X15	1	1
D 140		M91103017	オオフリコソクパンシメネジ 11/64(40)X24	Screw 11/64(40)X24	2	2
D 141		MB18B8601	オオフリコソクメンイタ (B)	Large pendulum side plate	1	1
D 142		MB18B7601	オオフリコソクメンイタ (A)	Large pendulum side plate	1	1
D 143		M96031021	ロッククアナツキホルト 15/64(28)	Bolt 15/64(28)	1	1
D 144		ME18A0950	レバーイタ	Lever	1	1
D 145		M94006021	トメネジ M4X6	Screw M4X6	1	1
D 146		M91007045	ナット M4	Nut M4	1	1
D 147		M91012004	プラマイナネジ M4X35	Screw M4X35	1	1
D 148		M94026017	セフティソケット M4X8	Bolt M4X8	4	4
D 149		ME10A0705	ハネオサエイタ	Spring holder	1	1
D 150		ME18A0572	ツルマキバネ	Spring	1	1
D 151	B	M94019017	セフティソケット M4X14	Bolt M4X14	2	2
D 152		ME10A0154	アンナイダイ	Adapter	1	1
D 153		M90331060	ピン	Pin	1	1
D 154		ME18A0300	カイホウウデ	Bobbin opener	1	1
D 155		ME18A0454	ツハツキジク	Shaft	1	1
D 156	C	M91505002	ヒラネジ 15/64(28)X13.5	Screw 15/64(28)X13.5	1	1
D 901		MB18E0450	シタジククミタテ	Hook shaft assy.	1	1

**E** 中押え機構  
**PRESSER BAR LIFTING MECHANISM**

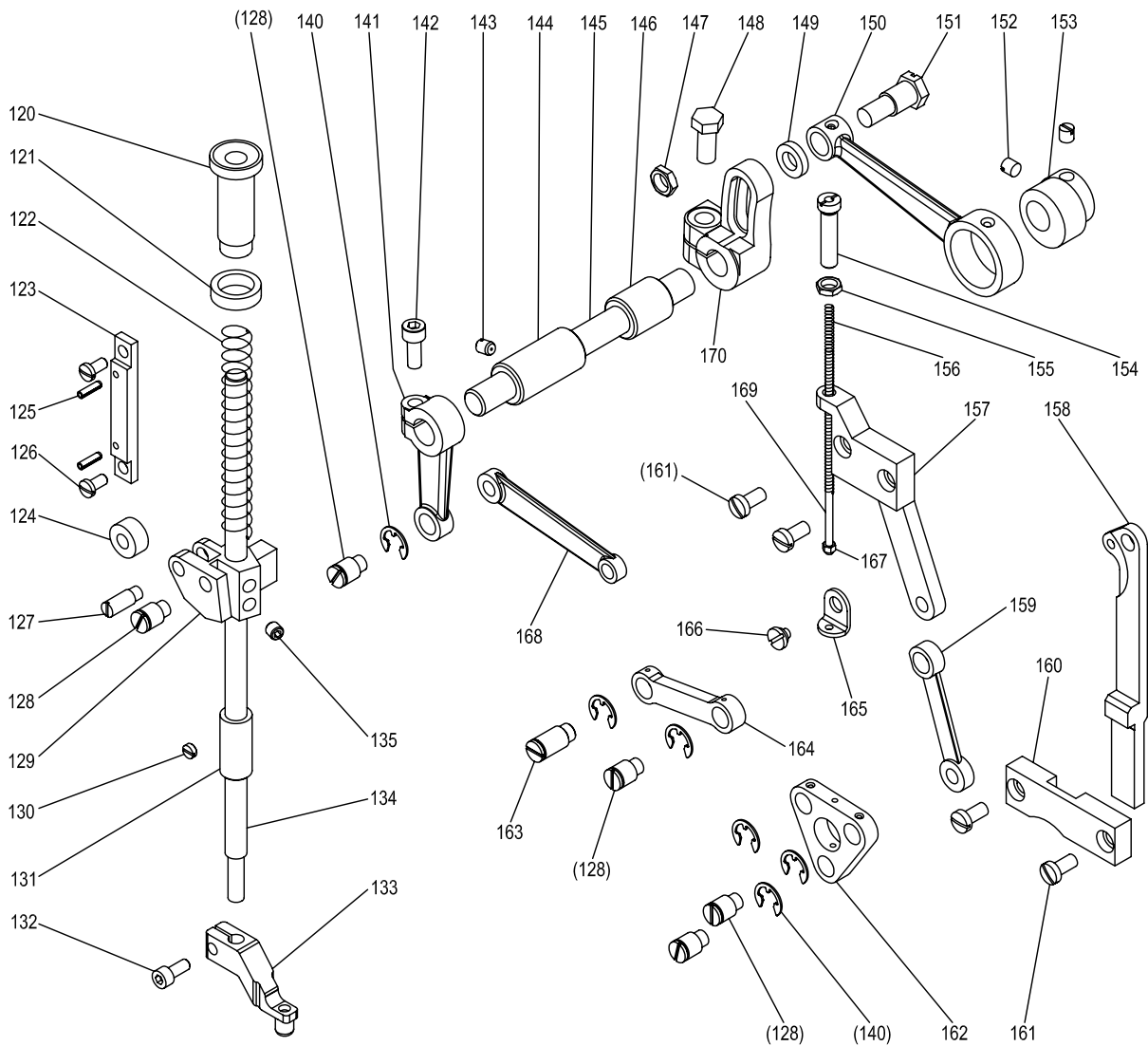
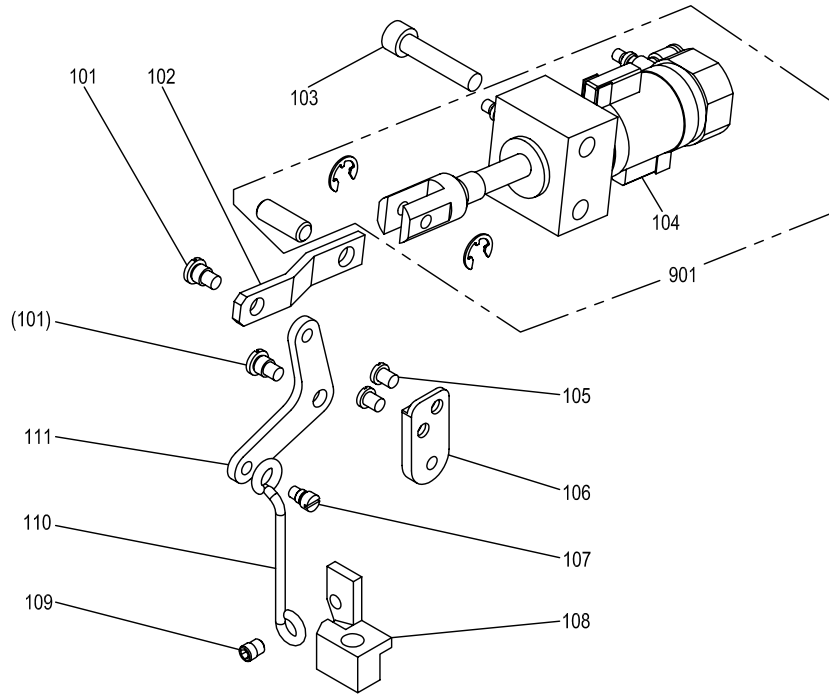

## [E] 中押え機構

## PRESSER BAR LIFTING MECHANISM

Fig no.	変更 Mod.	部品コード Parts no.	品名	Description	数量	
					Amt. 1008H	Req. 2008H
E 101		M91528015	ダンネジ 15/64(28)X10.3	Screw 15/64(28)X10.3	2	2
E 102		MB18A0725	ヒキアケテコ	Lifting lever	1	1
E 103		M98005017	セフティソケット M8X40	Bolt M8X40	2	2
E 104		MB18F2501	オートスイッチミタテ	Auto switch assy.	1	1
E 105		M91510003	マルヒラネジ 15/64(28)X7	Screw 15/64(28)X7	2	2
E 106		MB18A0912	ヒキアケリンクダイ	Lifting link adapter	1	1
E 107		M91525002	ヒキアケホウネジ 15/64(28)	Knee lifter rod screw 15/64(28)	1	1
E 108		MB18A1254	オサエアケテコ	Lifting lever	1	1
E 109		M96032021	ロッカクアナツキホルト 1/4(40)	Bolt 1/4(40)	1	1
E 110		MB18A1784	ヒキアケホウ	Knee lifter rod	1	1
E 111		MB18A4910	ヒキアケリンク	Lifting link	1	1
E 120		MB18A0261	オサエチヨウセツネジ	Thumb screw	1	1
E 121		MB18A1261	オサエチヨウセツネジセット	Presser bar screw set	1	1
E 122		MB18A0259	オサエチヨウセツバネ	Presser bar spring	1	1
E 123		MB18A0265	オサエホウダキコロガイドハン	Presser bar guide plate	1	1
E 124		MB18A0973	ローラーフォロア	Roller follower	1	1
E 125		M90305064	スプリングピン 3X12	Spring pin 3X12	2	2
E 126		M91252003	マルヒラネジ 3/16(32)X9.5	Screw 3/16(32)X9.5	2	2
E 127		MB18A0254	オサエホウダキコロガイドシク	Presser bar guide shaft	1	1
E 128		MB18A1454	ウワオクリリンクシク	Top feed link shaft	5	5
E 129		MB18A1265	オサエホウダキ	Presser bar lifting bracket	1	1
E 130		M91633001	トメネジ 1/4(40)X2.5	Screw 1/4(40)X2.5	1	1
E 131		MB18A1664	ハリホウオサエホウシタメタル	Bushing for presser bar lower	1	1
E 132		M95002017	セフティソケット M5X12	Bolt M5X12	1	1
E 133		MB18A0256	オサエ	Clamp frame	1	1
E 134		MB18A0262	オサエホウ	Presser bar	1	1
E 135		M91634001	ロッカクアナツキトメネジ 1/4(40)X6	Screw 1/4(40)X6	2	2
E 140		M90808065	Eカトメワ	E-type retaining ring	6	6
E 141		MB18A0274	ウワオクリウデ (マエ)	Top feed rock shaft crank (front)	1	1
E 142		M96030021	ロッカクアナツキホルト M6X15	Bolt M6X15	1	1
E 143		M91525001	トメネジ 15/64(28)X7	Screw 15/64(28)X7	2	2
E 144		MB18A0232	ウワオクリシクマエメタル	Top feed rock shaft metal (left)	1	1
E 145		MB18A0284	ウワオクリシク	Top feed rock shaft	1	1
E 146		MB18A0287	ウワオクリシクウシロメタル	Top feed rock shaft metal (right)	1	1
E 147		M93301045	ロッカクナット 11/32(28)	Nut 11/32(28)	1	1
E 148		M92006022	ロッカクホルト 5/16(18)X18	Bolt 5/16(18)X18	1	1
E 149		M90831050	ウワオクリロッドダンネジサガネ	Washer	1	1
E 150		MB18A1293	ウワオクリロッド	Top feed rod	1	1
E 151		M90301017	ウワオクリロッドダンネジ	Screw	1	1
E 152		M91635001	トメネジ 1/4(40)X6	Screw 1/4(40)X6	2	2
E 153		MB18A0461	ジョウゲカム	Top feed lifting cam	1	1
E 154		M91802035	ウワオクリバチヨウセツネジ	Screw	1	1
E 155		M91808045	ロッカクナット 9/32(28)	Nut 9/32(28)	1	1
E 156		MB18A0557	ウワオクリチヨウセツバネ	Top feed regulator spring	1	1
E 157		MB18A0603	ウワオクリリンクダイ	Top feed link adapter	1	1
E 158		MB18A0293	ウワオクリロッド	Top feed rod	1	1
E 159		MB18A2910	ウワオクリリンク (A)	Top feed link (A)	1	1
E 160		MB18A0257	ウワオクリロッドオサエイタ	Top feed rod adapter	1	1
E 161		M91511003	マルヒラネジ 15/64(28)X12	Screw 15/64(28)X12	4	4
E 162		MB18A0590	サンカケテコ	Triangle lever	1	1
E 163		M92003015	ウワオクリロッドダンネジ	Screw	1	1
E 164		MB18A1910	ウワオクリリンク (B)	Top feed link (B)	1	1
E 165		MB18A0702	ウワオクリバネウケ	Top feed spring supporter	1	1
E 166		M91701015	ダンネジ 11/16(40)X4.9	Screw 11/16(40)X4.9	1	1
E 167		M90854045	ロッカクナット 1/8(44)	Nut 1/8(44)	1	1
E 168		MB18A0462	ジョウゲメガネ	Top feed lifting link	1	1
E 169		MB18A0784	ウワオクリバネシンホウ	Top feed spring shaft	1	1
E 170		MB18A0275	ウワオクリウデ (ウシロ)	Top feed rock shaft crank (rear)	1	1
E 901		MB18F3434	エアシリンダクミタテ	Air cylinder assy.	1	1

**F** 上系切り機構(1)  
 UPPER THREAD TRIMMER MECHANISM(1)

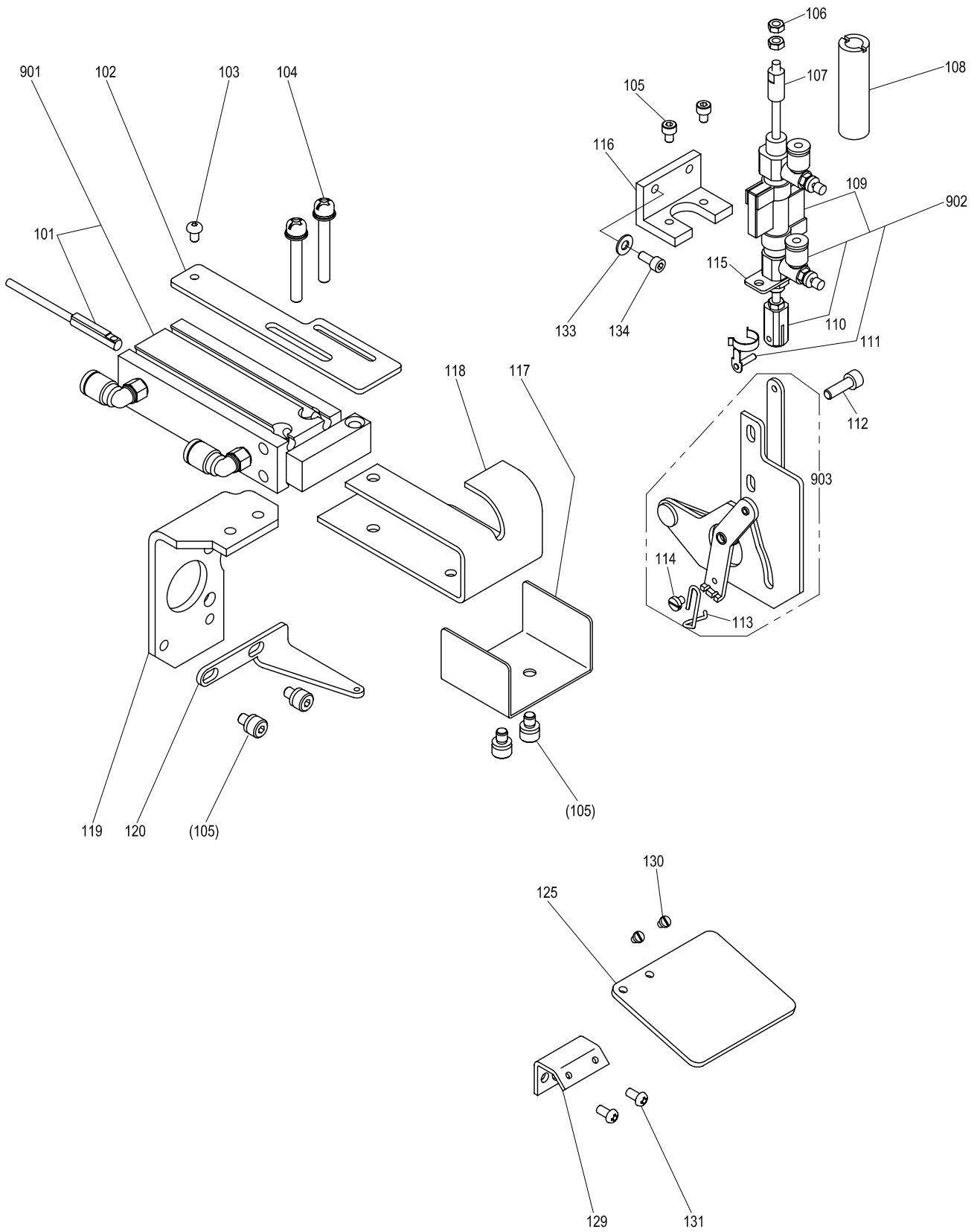

[F]上糸切り機構(1)

UPPER THREAD TRIMMER MECHANISM(1)

Fig no.	変更 Mod.	部品コード Parts no.	品名	Description	数量	
					Amt. Req. 1000H	2008H
F 101		MB18E9501	オートスイッチクミタテ	Auto switch assy.	1	1
F 102		MB18C2601	イトチョウセツイタ	Thread take-up guide	1	1
F 103		M91608022	ボルト M3X5	Bolt M3X5	1	1
F 104	B	M91276004	SW-PWフライマインネジ M4X30	Screw M4X30	2	2
F 105		M94008017	セフティソケット M4X6	Bolt M4X6	6	6
F 106		M90875045	ナット M3	Nut M3	2	2
F 107		MB18A3477	ストップ	Stopper	1	1
F 108	C	ME18A0339	カバー	Cover	1	1
F 109		MB18F0501	オートスイッチクミタテ	Auto switch assy.	1	1
F 110		MB18A3621	Yカタナックル	Y-knuckle	1	1
F 111		M90323063	クレビスピン	Crevice pin	1	1
F 112		M95002017	セフティソケット M5X12	Bolt M5X12	2	2
F 113		MB18A0980	ワイパー	Wiper	1	1
F 114		M90922002	ヒラネジ 9/64(40)X8	Screw 9/64(40)X8	1	1
F 115		MB18B2601	シリンダトリツケイタ	Cylinder bracket	1	1
F 116	C	ME18A0982	ワイパーシリンダダイ	Wiper cylinder adapter	1	1
F 117		MB18B1339	カバー	Cover	1	1
F 118		MB18B0339	イトヒキダシカバー	Cover	1	1
F 119		MB18C3601	イトヒキダシトリツケイタ	Adapter	1	1
F 120		MB18A1216	ウワイトアンナイ	Thread guide	1	1
F 125		MB18A0160	アイガード	Eye guard	1	1
F 129		MB60A0601	アイガードトリツケイタ	Eye guard adapter	1	1
F 130		M90806002	ヒラネジ 1/8(44)X6	Screw 1/8(44)X6	2	2
F 131		M90358037	Pナネジ M4X8	Screw M4X8	2	2
F 133	C	M90421050	サガネ 4	Washer 4	2	2
F 134	C	M94001017	セフティソケット M4X10	Bolt M4X10	2	2
F 901		MB18F0434	エアシリンダクミタテ	Air cylinder assy.	1	1
F 902		MB18F1434	エアシリンダクミタテ	Air cylinder assy.	1	1
F 903		MB18E0982	ワイパークミタテ	Wiper assy.	1	1

**G** 上系切り機構(2)  
 UPPER THREAD TRIMMER MECHANISM(2)

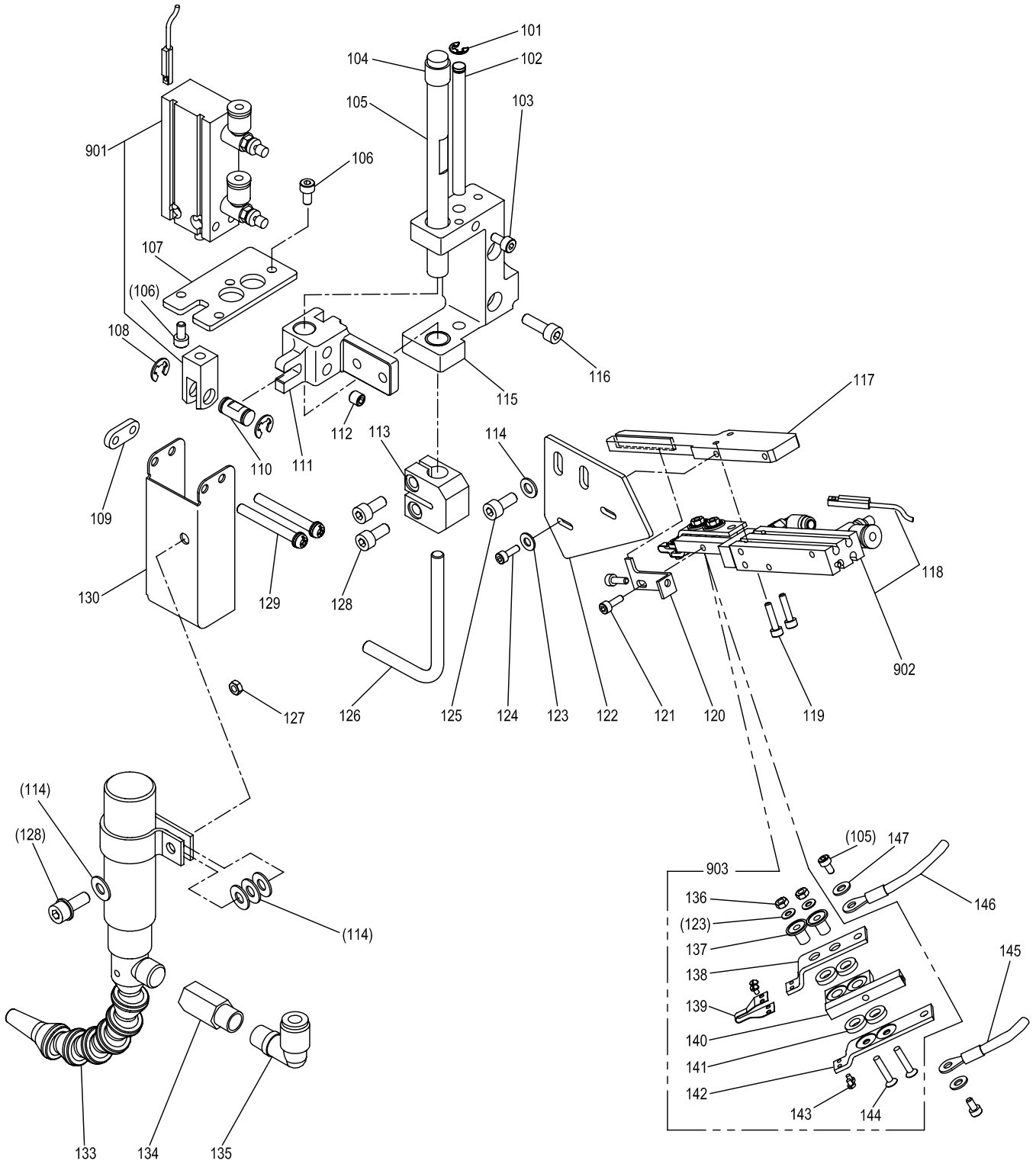

[G]上糸切り機構(2)

UPPER THREAD TRIMMER MECHANISM(2)

Fig no.	変更 Mod.	部品コード Parts no.	品名	Description	数量	
					Amt. 1000H	Req. 2008H
G 101		M90504065	E <sup>カ</sup> 外メ <sup>ワ</sup> 4	E-type retaining ring 4	1	1
G 102		MB18A1157	アンナイホ <sup>ウ</sup>	Shaft	1	1
G 103		M94013017	セフテイソケット M4X12	Bolt M4X12	1	1
G 104		MA21P0750	ブッシュ	Bushing	2	2
G 105		MB18B4454	ジク	Shaft	1	1
G 106		M94002017	セフテイソケット M4X8	Bolt M4X8	6	6
G 107		MB18M9601	シリンダ <sup>ト</sup> リツケイ <sup>タ</sup>	Cylinder adapter	1	1
G 108		M90511065	E <sup>カ</sup> 外メ <sup>ワ</sup> 6	E-type retaining ring 6	2	2
G 109		MB18C0601	ネジ <sup>イ</sup> タ	Adapter	1	1
G 110		MB18B5454	ピン	Pin	1	1
G 111		MB18A0200	イ <sup>ト</sup> ウ <sup>タ</sup> イ	Adapter	1	1
G 112		M91650020	ロツカクアナツキトメネジ <sup>シ</sup> M6X8	Screw M6X8	2	2
G 113		MB18A4603	アンシュ <sup>ラ</sup> ク <sup>ダ</sup> キ	Supporter holder	1	1
G 114	C	M90511050	サ <sup>カ</sup> ネ 5	Washer 5	6	6
G 115		MB18A5603	アンシュ <sup>ラ</sup> ク <sup>ダ</sup> イ	Adapter	1	1
G 116		M95006021	ロツカクアナツキホル <sup>ト</sup> M5X30	Bolt M5X30	2	2
G 117		MB18A1154	アンナイイ <sup>タ</sup>	Guide plate	1	1
G 118		MB18E8501	オ <sup>ト</sup> ス <sup>イ</sup> ツ <sup>チ</sup> ク <sup>ミ</sup> タ <sup>テ</sup>	Auto switch assy.	1	1
G 119		M94004017	セフテイソケット M3X16	Bolt M3X16	2	2
G 120		MB18A0802	マ <sup>ワ</sup> リ <sup>ト</sup> メ <sup>イ</sup> タ	Rock plate	1	1
G 121		M94003017	セフテイソケット M3X6	Bolt M3X6	2	2
G 122		MB18C1601	トリツケイ <sup>タ</sup>	Plate	1	1
G 123		M90316050	ミ <sup>カ</sup> キ <sup>サ</sup> ガ <sup>ネ</sup> 3	Washer 3	4	4
G 124		M94005017	セフテイソケット M3X10	Bolt M3X10	2	2
G 125		M95002017	セフテイソケット M5X12	Bolt M5X12	3	3
G 126		MB18A0150	ア <sup>ン</sup>	Supporter	1	1
G 127		M91382045	ナ <sup>ツ</sup> ト M5	Nut M5	1	1
G 128		M95014021	セフテイソケット M5X14	Bolt M5X14	3	3
G 129		M90446037	コ <sup>ネ</sup> ジ <sup>シ</sup> M4X40	Screw M4X40	2	2
G 130	C	ME18A1339	カ <sup>バ</sup> ー	Cover	1	1
G 133		MB18A1434	ク <sup>ー</sup> ラ <sup>ー</sup>	Cooler	1	1
G 134		MB18A0571	イ <sup>ケ</sup> イ <sup>ソ</sup> ケ <sup>ツ</sup> ケ <sup>ツ</sup>	Special socket	1	1
G 135		MA30A0422	エ <sup>ル</sup> ホ <sup>ニ</sup> オ <sup>ン</sup>	Connector	1	1
G 136		M90875045	ナ <sup>ツ</sup> ト M3	Nut M3	2	2
G 137		M96101099	ゼ <sup>ツ</sup> エ <sup>ン</sup> ス <sup>リ</sup> ー <sup>ブ</sup>	Insulator sleeve	2	2
G 138		MB18A2601	イ <sup>タ</sup> (ウ <sup>エ</sup> )	Plate (upper)	1	1
G 139		MB18A0717	ヒ <sup>ー</sup> ト <sup>タ</sup> イ	Heater	1	1
G 140		M96301099	ゼ <sup>ツ</sup> エ <sup>ン</sup> ト <sup>ダ</sup> イ	Insulator base	1	1
G 141		M96201099	ゼ <sup>ツ</sup> エ <sup>ン</sup> ス <sup>ペ</sup> ー <sup>サ</sup>	Insulator spacer	4	4
G 142		MB18A0601	イ <sup>タ</sup> (シ <sup>タ</sup> )	Plate (lower)	1	1
G 143		M90672002	ヒ <sup>ラ</sup> ネ <sup>ジ</sup> M2X2.8	Screw M2X2.8	4	4
G 144		M90359037	サ <sup>ラ</sup> ネ <sup>ジ</sup> M3X16	Screw M3X16	2	2
G 145		M97344099	セ <sup>ツ</sup> ツ <sup>ク</sup> テ <sup>ン</sup> セ <sup>ン</sup> (ヒ <sup>ー</sup> タ <sup>ー</sup> ト <sup>ラ</sup> ン <sup>ス</sup> )	Cable (heater-trans)	2	2
G 146		M97343099	セ <sup>ツ</sup> ツ <sup>ク</sup> テ <sup>ン</sup> セ <sup>ン</sup> (ヒ <sup>ー</sup> タ <sup>ー</sup> ト <sup>ラ</sup> ン <sup>ス</sup> )	Cable (heater-trans)	2	2
G 147		M90421050	ミ <sup>カ</sup> キ <sup>サ</sup> ガ <sup>ネ</sup> 4	Washer 4	2	2
G 901		MB18F4434	エ <sup>ア</sup> シ <sup>リ</sup> ン <sup>ダ</sup> ク <sup>ミ</sup> タ <sup>テ</sup>	Air cylinder assy.	1	1
G 902		MB18E8434	エ <sup>ア</sup> シ <sup>リ</sup> ン <sup>ダ</sup> ク <sup>ミ</sup> タ <sup>テ</sup>	Air cylinder assy.	1	1
G 903		MB18E0199	イ <sup>ト</sup> キ <sup>リ</sup> ク <sup>ミ</sup> タ <sup>テ</sup>	Thread trimmer assy.	1	1

**H** 下系切り機構  
LOWER THREAD TRIMMER MECHANISM

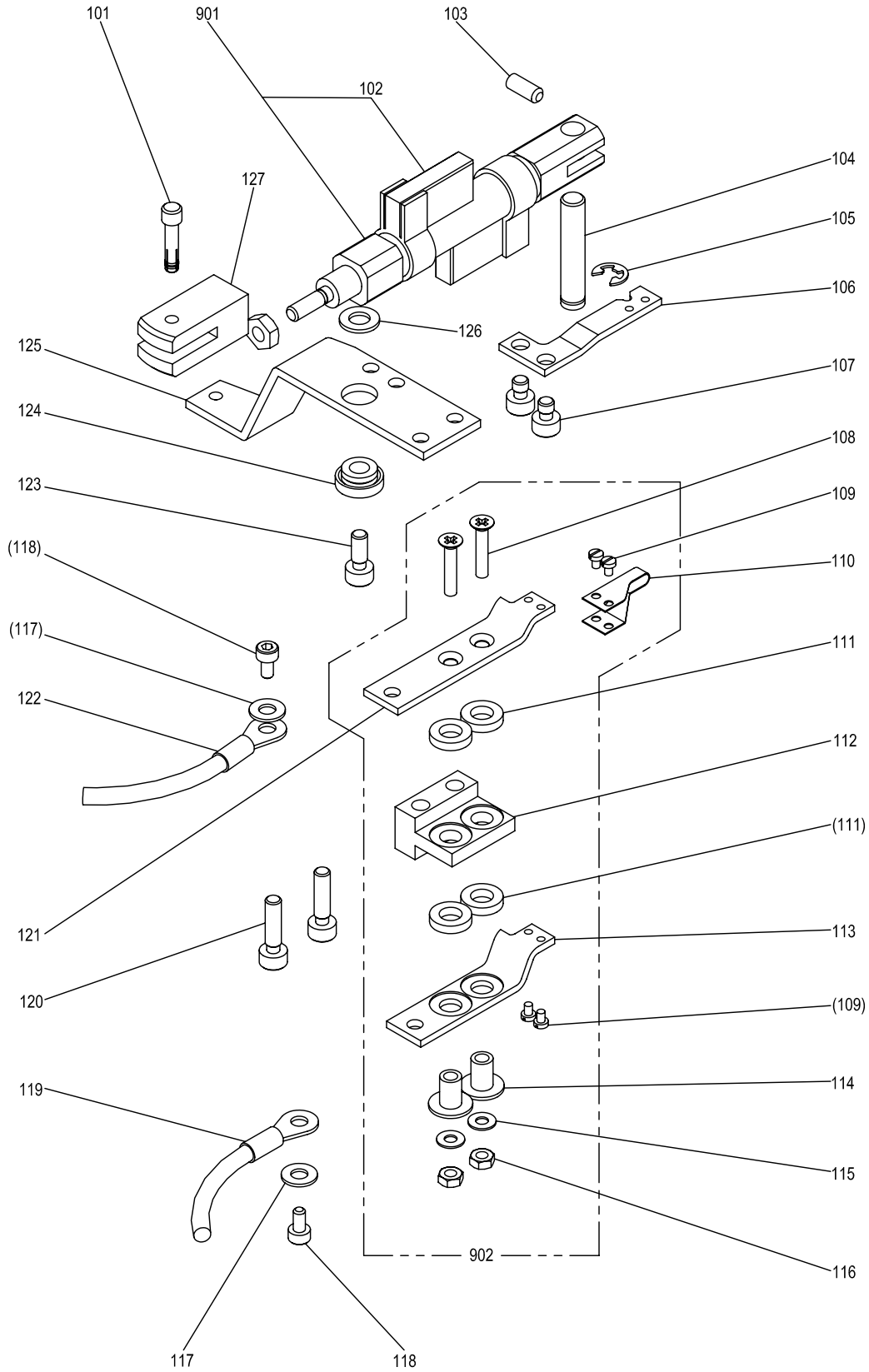

[H]下糸切り機構

LOWER THREAD TRIMMER MECHANISM

Fig no.	変更 Mod.	部品コード Parts no.	品名	Description	数量	
					Amt. 1000H	Req. 2008H
H 101		M90322063	クレビスピン	Crevice pin	1	1
H 102		MB18F1501	オートスイッチクミタテ	Auto switch assy.	1	1
H 103		M91058020	ロッククアナツキトメネジ M4X10	Screw M4X12	1	1
H 104		MB18B0454	シタイトキリシリンダササエピン	Pin	1	1
H 105		M90504065	Eカトメワ 4	E-type retaining ring 4	1	1
H 106		MB18B6601	シタイトクリダシタ	Lower thread let out plate	1	1
H 107		M94021017	セフティソケット M4X5	Bolt M4X5	2	2
H 108		M90359037	サラネジ M3X16	Screw M3X16	2	2
H 109		M90672002	ヒラネジ M2X2.8	Screw M2X2.8	4	4
H 110		MB18A0717	ヒートタイ	Heater	1	1
H 111		M96201099	ゼツインスペーサ	Insulator spacer	4	4
H 112		MB18A3603	シタイトヒートタイ	Heater adapter	1	1
H 113	B	MB18A0601	イタ(シタ)	Plate (lower)	1	1
H 114		M96101099	ゼツインスリーブ	Insulator sleeve	2	2
H 115		M90316050	ミガキサガネ 3	Washer 3	2	2
H 116		M90875045	ナット M3	Nut M3	2	2
H 117		M90421050	ミガキサガネ 4	Washer 4	2	2
H 118		M94008017	セフティソケット M4X6	Bolt M4X6	2	2
H 119		M97343099	セツクデンセン(ヒータートランス)	Cable (heater-trans)	1	1
H 120		M94022017	セフティソケット M4X15.5	Bolt M4X15.5	2	2
H 121		MB18A2601	イタ(ウエ)	Plate (upper)	1	1
H 122		M97344099	セツクデンセン(ヒータートランス)	Cable (heater-trans)	1	1
H 123	C	M95005017	セフティソケット M5X10	Bolt M5X10	1	1
H 124		MB18A0750	ブッシュ	Bushing	1	1
H 125		MB18E0436	シタイトヨウトウイタクミタテ	Rock plate	1	1
H 126		M90518050	サガネ φ5.5(φ12)X1.2	Washer φ5.5(φ12)X1.2	1	1
H 127		MB18A0621	Yガタナックル	Y-knuckle	1	1
H 901		MB18F2434	エアシリンダクミタテ	Air cylinder assy.	1	1
H 902		MB18E1717	シタイトキリヒータクミタテ	Lower trimmer assy.	1	1

**J** 糸調子機構  
**THREAD GUIDE MECHANISM**

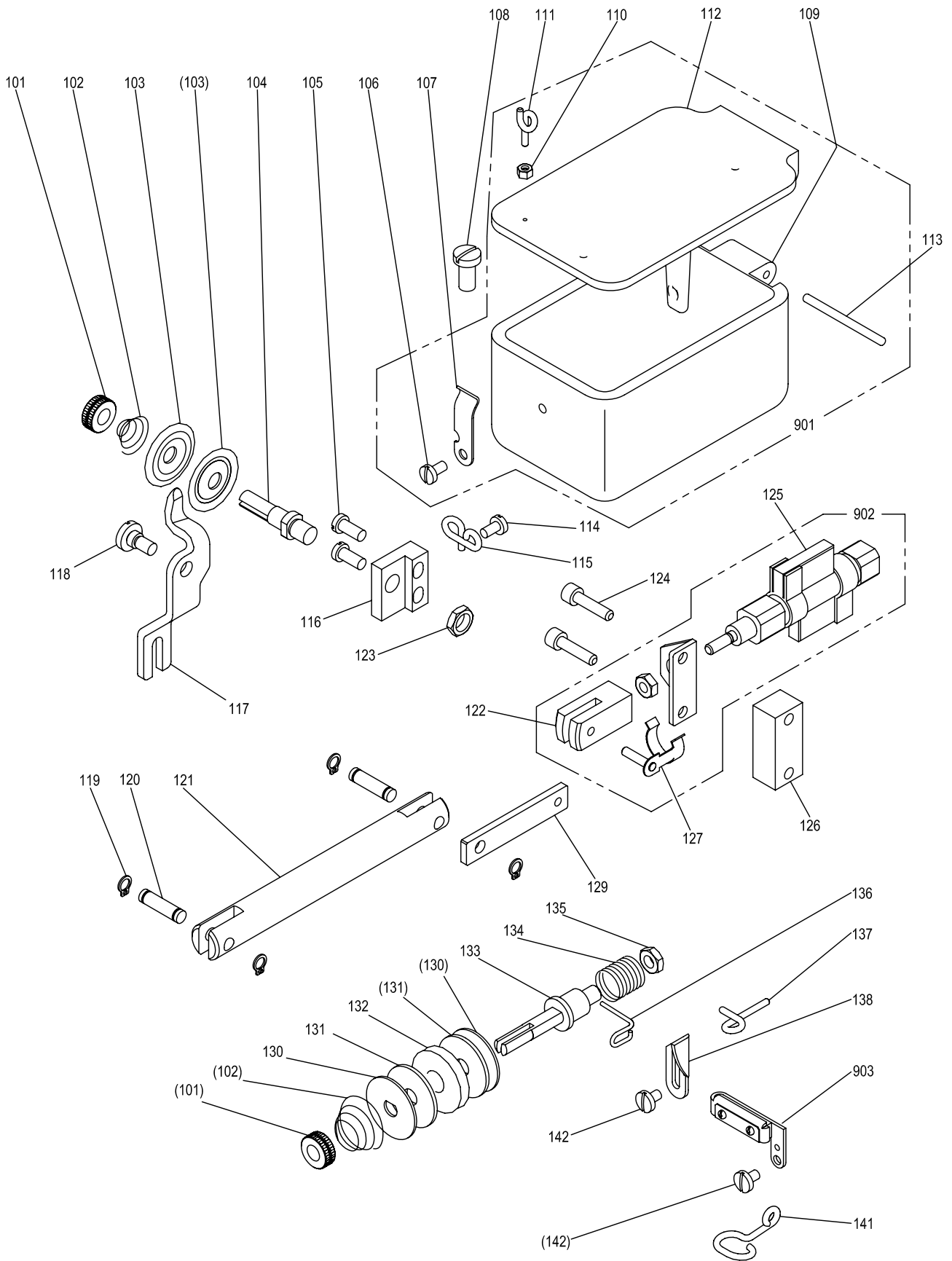

[J]糸調子機構  
THREAD GUIDE MECHANISM

Fig no.	変更 Mod.	部品コード Parts no.	品名	Description	数量	
					Amt. 1000	Req. 2008H
J 101	M91612046		イトチョウシナット	Tension nut	2	2
J 102	MB18A0192		イトチョウシバネ	Bobbin thread tension spring	2	2
J 103	MB18A0555		イトチョウシガラ	Thread tension disc	2	2
J 104	MB18A0213		イトチョウシボウ	Tension stud	1	1
J 105	M91129003		マルヒラネジ 11/64(40)X10.5	Screw 11/64(40)X10.5	2	2
J 106	M90948003		マルヒラネジ 9/64(40)X6.8	Screw 9/64(40)X6.8	1	1
J 107	MB18A1259		ローオサエイタハネ	Leaf spring	1	1
J 108	M91511003		マルヒラネジ 15/64(28)X12	Screw 15/64(28)X12	1	1
J 109	MB18A3138		アブラツボ	Oil pot	1	1
J 110	M90503045		ロックナット 3/32(56)	Nut 3/32(56)	1	1
J 111	MB18A4180		テンピンイトアンナイ (B)	Thread guide (B)	1	1
J 112	MB18A2138		アブラツボフタ	Oil pot cover	1	1
J 113	M90329060		トピン	Pin	1	1
J 114	M90948003		マルヒラネジ 9/64(40)X6.8	Screw 9/64(40)X6.8	2	2
J 115	MB18A0180		イトチョウシイトアンナイ	Thread tension	1	1
J 116	MB18A0211		イトチョウシダイ	Thread tension stand	1	1
J 117	MB18A0221		イトユルメイタ	Tension release plate	1	1
J 118	M91770015		ダンツキヒラネジ 3/16(28)X10.7	Screw 3/16(28)X10.7	1	1
J 119	M90331065		Cガトメワ 5	C-type retaining ring 5	4	4
J 120	MB18A0223		イトユルメピン 3.8X46	Thread releasing pin 3.8X46	2	2
J 121	MB18B2454		イトユルメジク	Shaft	1	1
J 122	MB18A3621		Yガタナックル	Y-knuckle	1	1
J 123	M91808045		ロックナット 9/32(28)	Nut 9/32(28)	1	1
J 124	M94014017		セフティソケット M4X18	Bolt M4X18	2	2
J 125	MB18F3501		オートスイッチクミタテ	Auto switch assy.	1	1
J 126	MB18A1603		イトユルメリツケダイ	Thread releasing bracket	1	1
J 127	M90323063		クレビスピン	Crevice pin	1	1
J 129	MB18A5910		イトユルメリンク	Link	1	1
J 130	MB18A1257		イトアンナイグルマフェルトオサエイタ	Thread guide ring clamp flame	2	2
J 131	MB18A1740		イトアンナイグルマフェルト	Thread guide ring felt	2	2
J 132	MB18A0175		イトアンナイグルマ	Thread guide ring	1	1
J 133	MB18A1213		イトチョウシシタジク	Thread tension under shaft	1	1
J 134	MB18A0187		イトトリバネ (B)	Thread take-up spring (B)	1	1
J 135	M91508045		ロックナット 15/64(28)	Nut 15/64(28)	1	1
J 136	MB18A1187		イトトリバネ (A)	Thread take-up spring (A)	1	1
J 137	MB18A0216		オオイトカケ	Thread guide	1	1
J 138	MB18A1702		イトトリバネウケイタ	Thread take-up spring plate	1	1
J 141	MB18A2180		イトアンナイ	Thread guide	1	1
J 142	M90947003		マルヒラネジ 9/64(40)X6	Screw 9/64(40)X6	2	2
J 901	MB18E0138		アブラツボクミタテ	Oil pot assy.	1	1
J 902	MB18F5434		エアシリンダクミタテ	Air cylinder assy.	1	1
J 903	MB18E1180		イトアンナイクミタテ	Thread guide assy.	1	1

**K** 糸巻き装置機構  
BOBBIN WINDER MECHANISM

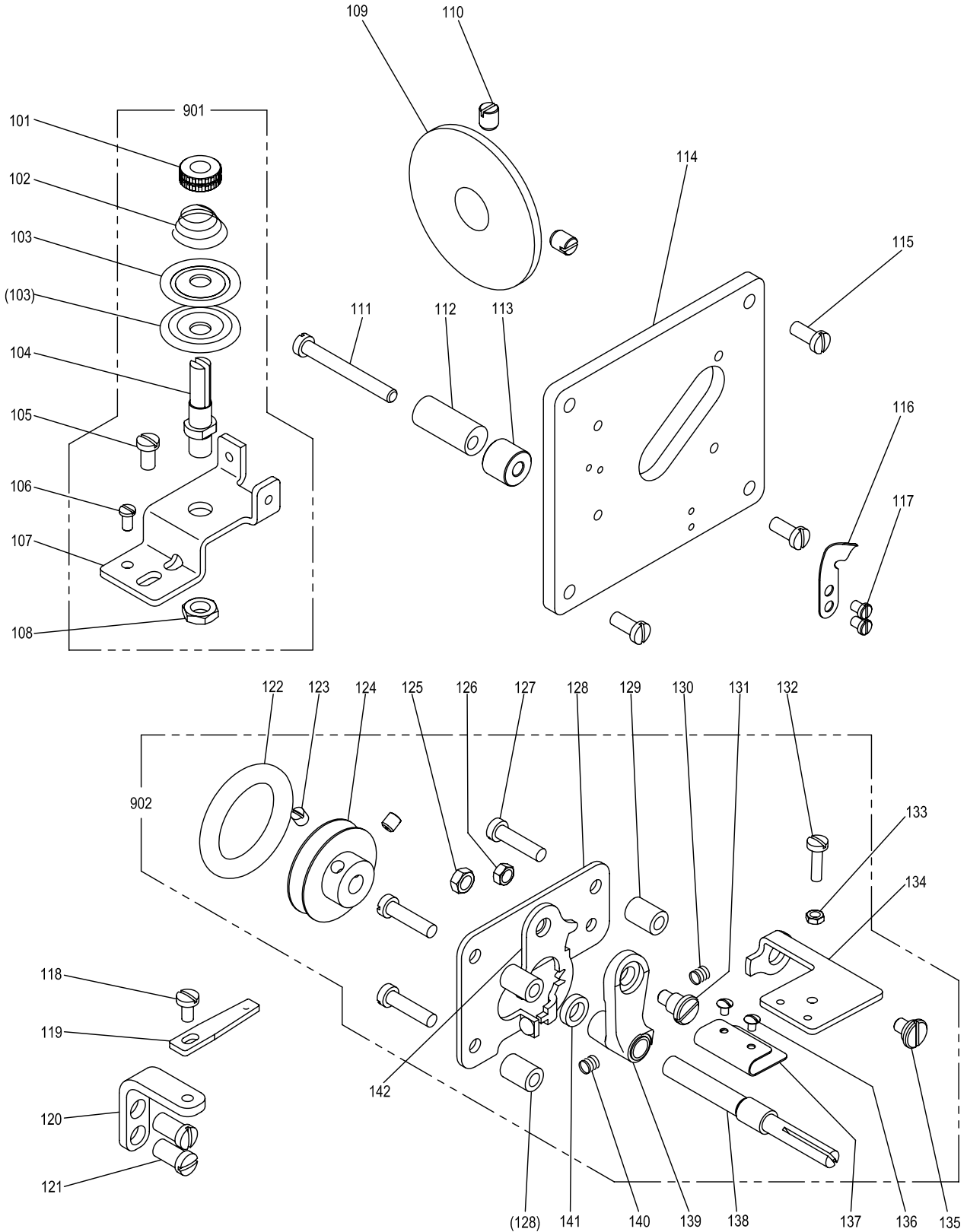

[K]糸巻き機構  
BOBBIN WINDER MECHANISM

Fig no.	変更 Mod.	部品コード Parts no.	品名	Description	数量	
					Amt. 1000	Req. 2008H
K 101		M91612046	イトチョウシナット	Tension nut	1	1
K 102	B	MB18A6192	イトチョウシハネ	Bobbin thread tension spring	1	1
K 103		MB18A0555	イトチョウシガラ	Thread tension disc	2	2
K 104		MB18A0213	イトチョウシホウ	Tension stud	1	1
K 105		M91144003	マルヒラネジ 11/64(40)X8.5	Screw 11/64(40)X8.5	1	1
K 106		M90824002	ナベネジ 1/8(44)	Screw M1/8(44)	1	1
K 107		MB18A0155	シタイトアンナイダイ	Lower thread guide adapter	1	1
K 108		M91808045	ロックナット 9/32(28)	Nut 9/32(28)	1	1
K 109		MB18A0194	イトマキマサツグルマ	Friction ring	1	1
K 110		M91525001	トメネジ 15/64(28)X7	Screw 15/64(28)X7	2	2
K 111		M91143003	マルヒラネジ 11/64(40)X38	Screw 11/64(40)X38	1	1
K 112		MB18A0190	イトマキストッパ	Bobbin winder stopper	1	1
K 113		MB18A0476	スペーサ	Spacer	1	1
K 114		MB18A0803	イトマキマトイタ	Bobbin winder plate	1	1
K 115		M91129003	マルヒラネジ 11/64(40)X10.5	Screw 11/64(40)X10.5	4	4
K 116		MB18A1196	イトキリホジハン	Thread trimmer holder	1	1
K 117		M90807003	ヒラネジ 1/8(44)X4	Screw 1/8(44)X4	2	2
K 118		M90948003	マルヒラネジ 9/64(40)X6.8	Screw 9/64(40)X6.8	1	1
K 119		MB18A0181	イトマキイトアンナイ	Bobbin winder thread guide	1	1
K 120		MB18A2603	イトマキイトアンナイトリツケダイ	Bobbin winder thread guide table	1	1
K 121		M91509003	マルヒラネジ 15/64(28)X11	Screw 15/64(28)X11	2	2
K 122		MB18A1194	イトマキグルママサツリン	Friction ring	1	1
K 123		M91116001	イトマキグルマトメネジ	Screw	2	2
K 124		MB18A2194	イトマキグルマ	Wheel	1	1
K 125		M91112045	ロックナット 11/64(40)	Nut 11/64(40)	1	1
K 126		M91207045	ロックナット 3/16(28)	Nut 3/16(28)	1	1
K 127		M91142003	マルヒラネジ 11/64(40)X18	Screw 11/64(40)X18	3	3
K 128		MB18A0189	イトマキダイ	Bobbin winder bracket	1	1
K 129		M90455050	イトマキダイトリツケサガネ	Washer	3	3
K 130		MB18A0700	イトマキシクダイハネ	Spring	1	1
K 131		M91145015	イトマキウデタンネジ	Screw	1	1
K 132		M90806003	マルヒラネジ 1/8(44)X12.5	Screw 1/8(44)X12.5	1	1
K 133		M90855045	ロックナット 1/8(44)	Nut 1/8(44)	1	1
K 134		MB18A5192	ホビンオサエ	Spring plate for bobbin winder	1	1
K 135		M91111015	タンネジ 11/64(40)X6.2	Screw 11/64(40)X6.2	1	1
K 136		M90608003	ハインドネジ 3/32(56)	Screw 3/32(56)	2	2
K 137		MB18A1192	ホビンオサエハネ	Presser spring bobbin	1	1
K 138		MB18A0191	イトマキシク	Shaft	1	1
K 139		MB18A1191	イトマキウデ	Bobbin winder arm	1	1
K 140	B	MB18A1700	マキアケハネ	Spring	1	1
K 141		MB18A0352	イトマキグルマカラー	Collar	1	1
K 142		MB18A0551	イトマキシクダイチョウセツイタ	Thread tension regulator plate	1	1
K 901		MB18E0155	シタイトアンナイダイクミタテ	Lower thread guide adapter assy.	1	1
K 902		MB18E0190	イトマキダイクミタテ	Bobbin winder bracket assy.	1	1

**L** X-Yテーブル機構  
 X-Y TABLE MECHANISM

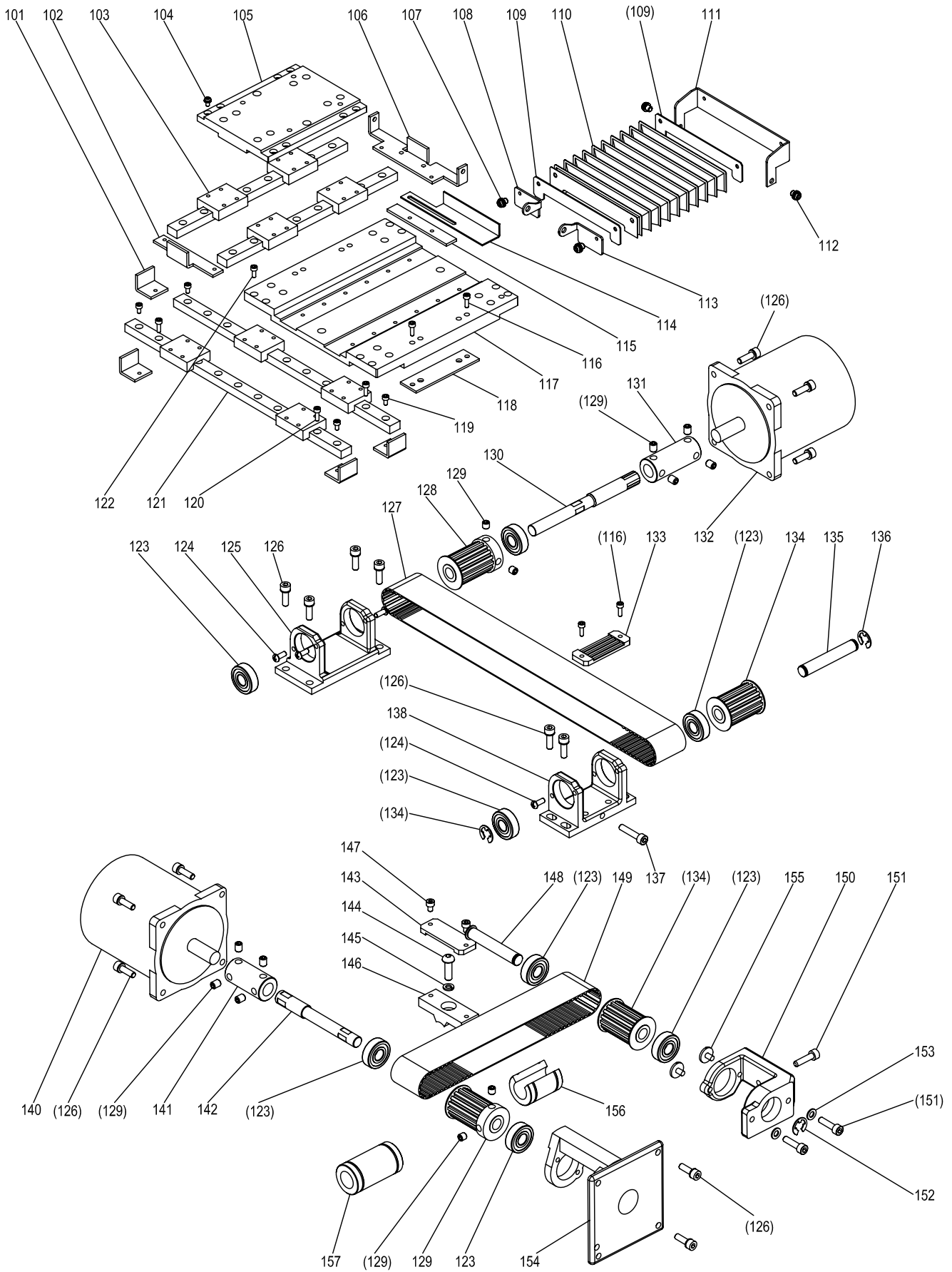

[L]X-Yテーブル機構  
X-Y TABLE MECHANISM

Fig no.	変更 Mod.	部品コード Parts no.	品名	Description	数量	
					Amt. 1000H	Req. 2008H
L 101		MB18A2477	Xジクストッパ	X-stopper	4	4
L 102		MB18A1477	Yジクストッパ	Y-stopper	1	1
L 103	B	MB18A4920	スライドガイド	Slide guide	2	2
L 104		M90859004	SW-PWフライナヘネジ M3X6	Screw M3X6	16	16
L 105	C	ME18A0957	Yイトウレース	Y-movable race	1	1
L 106		MB18A0477	Yジクストッパ	Y-stopper	1	1
L 107		M90859004	SW-PWフライナヘネジ M3X6	Screw M3X6	6	6
L 108		MB18B4601	ジャハラトリツケイタ FL	Shutter adapter (FL)	1	1
L 109		MA20A0257	オサエイタ	Shutter holder	2	2
L 110		MB18A0458	ジャハラ	Shutter	1	1
L 111		MB18B3601	ジャハラトリツケイタ R	Shutter adapter (R)	1	1
L 112		M91058004	SW-PWフライナヘネジ M4X6	Screw M4X6	2	2
L 113		MB18B5601	ジャハラトリツケイタ FR	Shutter adapter (FR)	1	1
L 114		MB18A0407	Xケンシュツイタ	X-detector plate	1	*
L 114	B	ME28A0407	Xケンシュツイタ	X-detector plate	*	1
L 115		MB18A4601	ネジイタ	Detector holder plate	1	1
L 116		M94006017	セフティソケット M4X16	Bolt M4X16	4	4
L 117		MB18E1957	Xイトウレース	X-movable race	1	*
L 117	B	ME28E0957	Xイトウレース	X-movable race	*	1
L 118		MB18A1476	スペーサ	Spacer	2	2
L 119		M94003017	セフティソケット M3X6	Bolt M3X6	10	10
L 120		M94005017	セフティソケット M3X10	Bolt M3X10	18	18
L 121	B	MB18A3920	スライドガイド	Slide guide	2	*
L 121	B	ME28A0920	スライドガイド	Slide guide	*	2
L 122		M94012017	セフティソケット M3X8	Bolt M3X8	12	12
L 123		MS02A2456	シールボールベアリング	Ball bearing	8	8
L 124		M91071004	SW-MWフライナヘネジ M4X8	Screw M4X8	10	10
L 125		MA30A0758	ブラケット	Bracket	1	1
L 126		M95004017	セフティソケット M5X16	Bolt M5X16	16	16
L 127		MB18A1523	タイミングベルト	Cog belt	1	1
L 128		MB45A0767	ベルトグルマ	Cog pulley	2	2
L 129		M96002001	ロッカクアナツキメネジ M6X6	Screw M6X6	10	10
L 130		MB18A2390	Xクトウシク	Driving shaft (X)	1	*
L 130	B	ME28A0390	Xクトウシク	Driving shaft (X)	*	1
L 131		MB18A2571	ジクツキテ	Coupling	1	*
L 131	B	MB18A1571	ジクツキテ	Coupling	*	1
L 132		M95056095	ステッピングモータ	Motor complete	1	1
L 133		MA35A1781	ベルトオサエ	Belt clamper	1	1
L 134		MB62A0767	ベルトグルマ	Cog pulley	2	2
L 135		MA21P0454	ジク	Shaft	1	1
L 136		M90604065	Eガタメワ 8	E-type retaining ring 5	2	2
L 137		M95011021	ロッカクアナツキホルト M5X25	Bolt M5X25	1	1
L 138		MA35A6758	ブラケット	Bracket	1	1
L 140	C	M95043095	ステッピングモータ	Motor complete	1	1
L 141		MB18A1571	ジクツキテ	Coupling	1	1
L 142		MB18A0390	Yクトウシク	Driving shaft (Y)	1	1
L 143		MB18E0778	ベルトオサエ	Belt clamper	1	1
L 144		M96061021	ロッカクアナツキホルタンホルト M6X20	Bolt M6X20	1	1
L 145		M90624053	ハネサガネ 6	Spring washer 6	1	1
L 146		MB18E0781	Yベルトダイ	Y-belt holder	1	1
L 147		M94001017	セフティソケット M4X10	Bolt M4X10	2	2
L 148		MS13A2454	ジュウトウシク	Shaft	1	1
L 149		MB18A0523	タイミングベルト	Cog belt	1	1
L 150		MS13A0758	ブラケット	Bracket	1	1
L 151		M95001017	セフティソケット M5X20	Bolt M5X20	3	3
L 152		M90516065	Cガタメワ 10	C-type retaining ring 10	1	1
L 153	C	M90511050	サガネ 5	Washer 5	2	2
L 154		MA45A5758	ブラケット	Bracket	1	1
L 155		M91119002	ヒラネジ 11/64(40)X6.8	Screw 11/64(40)X6.8	2	2
L 156		MB18A1921	リニアブッシュ	Bearing	1	1
L 157		MB18A0921	リニアブッシュ	Bearing	1	1

**M** 外押え機構  
 WORK HOLDER MECHANISM

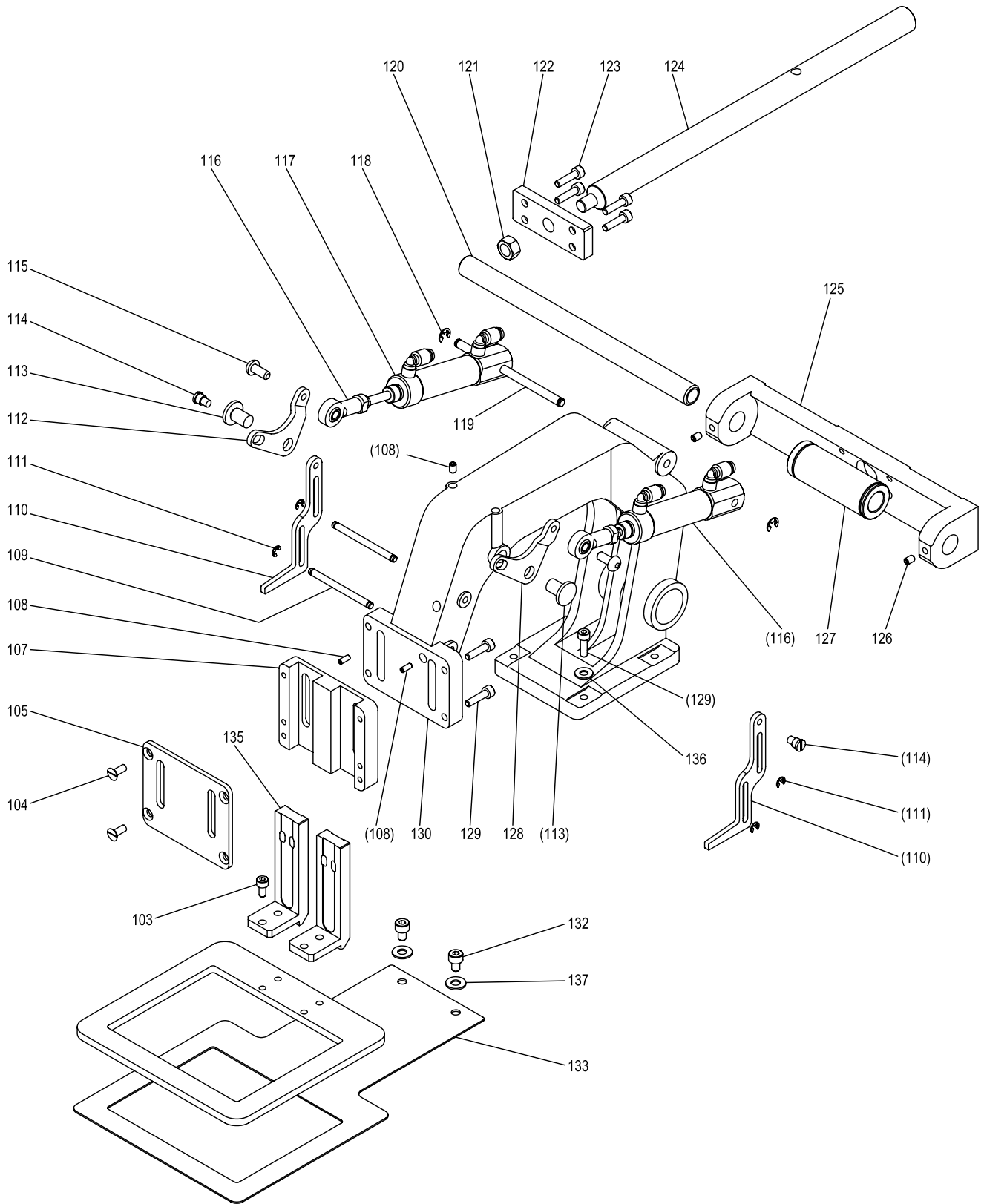

[M]外押え機構

WORK HOLDER MECHANISM

Fig no.	変更 Mod.	部品コード Parts no.	品名	Description	数量	
					Amt. 1008H	Req. 2008H
M 103		M94002017	セフテイツケット M4X8	Bolt M4X8	8	8
M 104	C	M94005037	Pサラネジ M4X8	Screw M4X8	4	4
M 105		MB18A2742	フタ	Cover	1	1
M 107		MB18A1263	オサエアンナイ	Work holder guide plate	1	1
M 108		M93001020	ロッカクアナツキトメネジ M3X6	Screw M3X6	4	4
M 109		MB18A5454	ピン	Pin	2	2
M 110		MB18A0252	オサエレバ	Pushing lever	2	2
M 111		M90512065	Eガトメワ 3	E-type retaining ring 3	4	4
M 112		MB18A0950	レバ	Lever	1	1
M 113	C	ME18A0454	ツハツキジク	Shaft	2	2
M 114		M91131015	ダンツキヒラネジ 11/64(40)X3.6	Hinged screw 11/64(40)X3.6	2	2
M 115	B	M95051021	ロッカクアナツキホタンホルト M5X12	Bolt M5X12	2	2
M 116	C	MB62A0975	ロッドエンド	Connecting link	2	2
M 117		MB18A0434	エアシリンダ	Air cylinder	2	2
M 118		M90504065	Eガトメワ 4	E-type retaining ring 4	2	2
M 119		MB18A4454	ピン	Pin	1	1
M 120		MB18B1454	ジク	Shaft	1	*
M 120	B	ME28A0454	ジク	Shaft	*	1
M 121		M92075045	ナット M8	Nut M8	1	1
M 122		MB18A0751	ブロック	Block	1	1
M 123		M94002017	セフテイツケット M4X8	Bolt M4X8	4	4
M 124		MB18A1390	Yクドウジク	Driving shaft (Y)	1	1
M 125		MB18E0455	ジクササエ	Shaft holder	1	*
M 125	B	ME28A0455	ジクササエ	Shaft holder	*	1
M 126		M91053020	ロッカクアナツキトメネジ M4X6	Screw M4X6	2	2
M 127		MB62A0921	リニアブッシュ	Bearing	1	1
M 128		MB18A1950	レバ	Lever	1	1
M 129	C	M94006017	セフテイツケット M4X16	Bolt M4X16	8	8
M 130		MB18A0263	オサエダイ	Work holder arm	1	1
M 132	C	M95003017	セフテイツケット M5X8	Bolt M5X8	2	2
M 133	C	ME18A0272	オクリイタ	Feed plate	1	*
M 133	C	ME28A1272	オクリイタ	Feed plate	*	1
M 134		MB18A3257	オサエイタ	Clamp frame	1	*
M 134	B	ME28A0257	オサエイタ	Clamp frame	*	1
M 135		MB18A1481	スライダー	Slider	2	2
M 136	C	M90421050	サガネ 4	Washer 4	4	4
M 137	C	M90512050	サガネ 5	Washer 5	2	2

**N** 配線配管機構(1)  
**CABLE AND AIR COMPONENTS(1)**

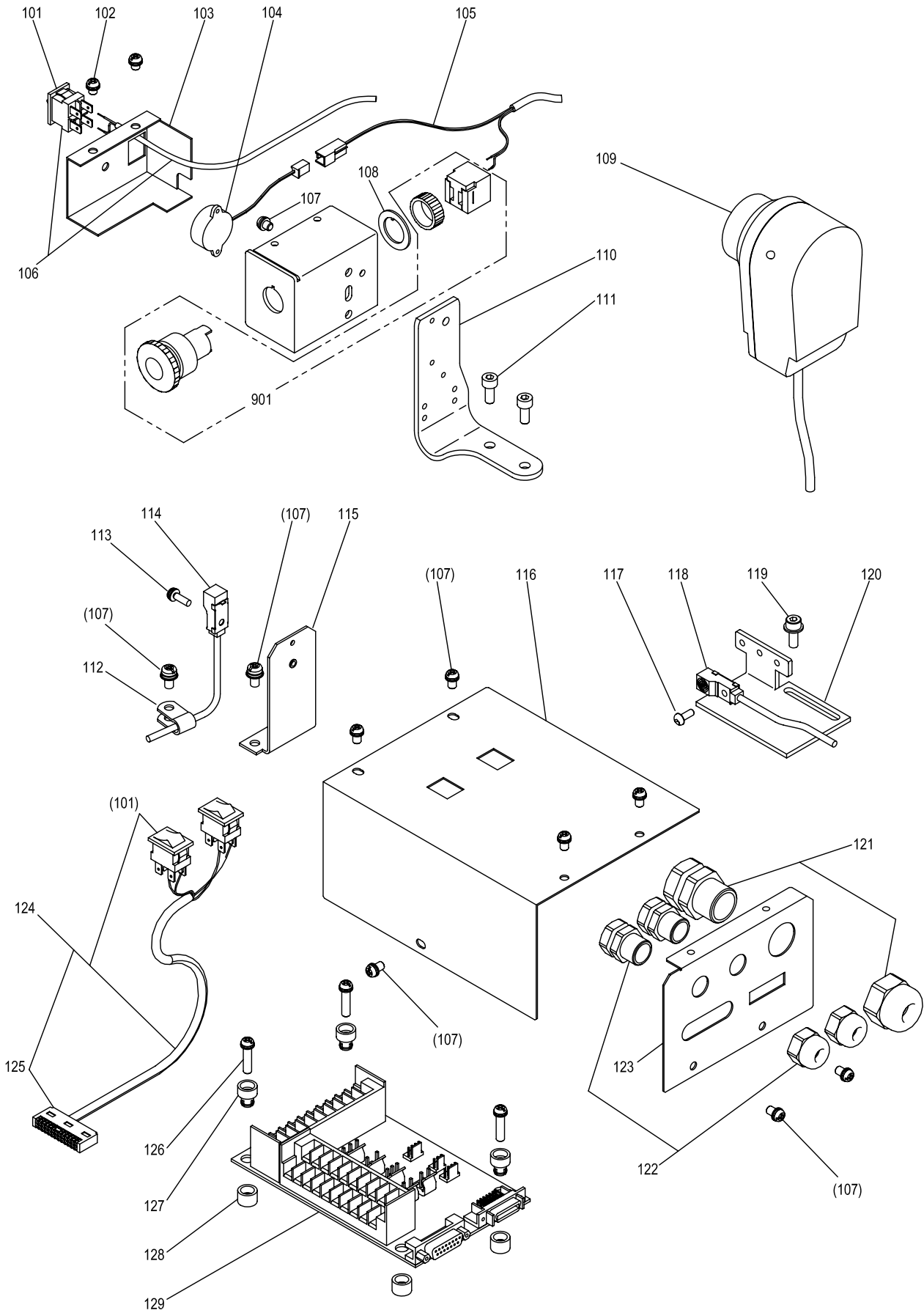

[N]配線配管機構(1)

CABLE AND AIR COMPONENTS(1)

Fig no.	変更 Mod.	部品コード Parts no.	品 名	Description	数量	
					Amt. Req. E1008H	Req. E2008H
N 101		M90118099	スイッチ	Switch	3	3
N 102		M91058004	SW-PWフライナヘネジ M4X6	Screw M4X6	1	1
N 103		MB48A0486	カバー	Cover	1	1
N 104	C	M97313099	ブザー	Buzzer	1	1
N 105		M97335099	セツクテンセンクミタテ	Connection wire assy.	1	1
N 106		M97336099	セツクテンセンクミタテ	Connection wire assy.	1	1
N 107		M91054004	SW-PWフライナヘネジ M4X8	Screw M4X8	10	10
N 108		MB60A0915	マワリメリング	Snap ring	1	1
N 109		MB18E0406	ウツクセンシュツキ	Detector assy.	1	1
N 110		MB18A3601	トリツケイタ	Adapter	1	1
N 111	B	M95005017	セフティソケット M5X10	Bolt M5X10	1	1
N 112	B	M94003099	ナイロンクリップ AB-3N	Nylon clip AB-3N	1	1
N 113		M90971004	SW-PWフライナヘネジ M3X10	Screw M3X10	2	2
N 114		ME10E0484	キンセツスイッチ X	Detector X	2	2
N 115		ME10A0408	ケンシュツダイ X	Detector bracket X	1	1
N 116		MB18A2339	Pハンカバー	Cover	1	1
N 117		M91606022	ロックアナツキボルト M3X10	Bolt M3X10	*	*
N 118		ME10E1484	キンセツスイッチ Y	Detector Y	1	1
N 119		M94001017	セフティソケット M4X10	Bolt M4X10	2	2
N 120	B	ME18A0408	Yケンシュツダイ	Detector bracket Y	1	1
N 121		MB60A5780	コードブッシュ (FGA-21L-12)	Cord bushing (large)	1	1
N 122		MB60A6780	コードブッシュ (FGA-13-08)	Cord bushing (small)	2	2
N 123		MB60A5601	コネクタトリツケイタ	Connector panel	1	1
N 124	C	M97341099	セツクテンセンクミタテ	Connection wire assy.	1	1
N 125		M91025099	コネクタ	Connector	1	1
N 126		M91057004	SW-PWフライナヘネジ M4X20	Screw M4X20	4	4
N 127		MB60A0366	ワシタツチブッシュ	Nylon bush	4	4
N 128		MB60A2352	ワシタツチブッシュ	Nylon bush	4	4
N 129	D	M800E2CON	Pハンクミタテ PLK-E2-CON	Print circuit board	1	1
N 901	B	ME10A0484	オンボルトスイッチ	Halt switch assy.	1	1

P 配線配管機構(2)  
CABLE AND AIR COMPONENTS(2)

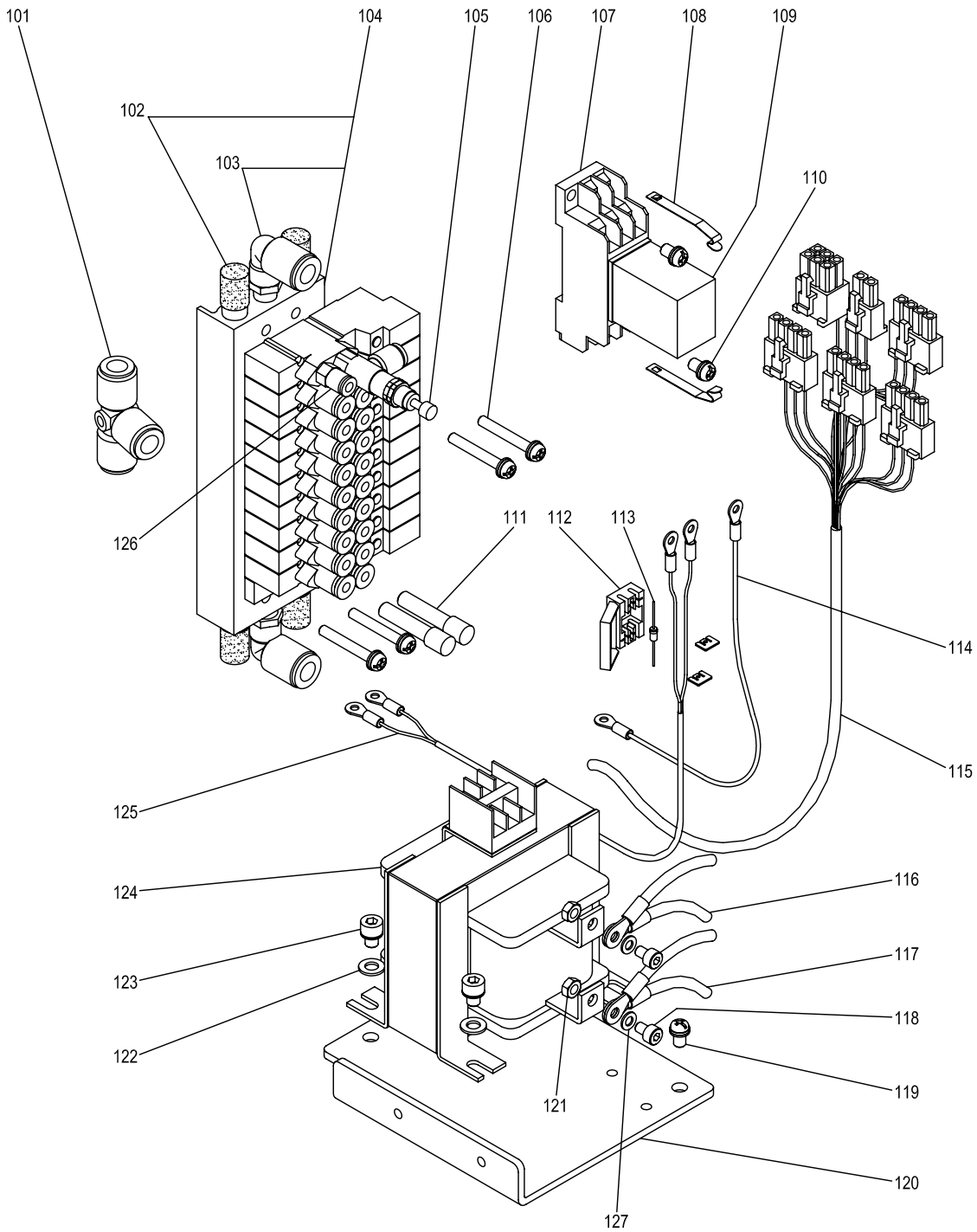

[P]配線配管機構(2)

CABLE AND AIR COMPONENTS(2)

Fig no.	変更 Mod.	部品コード Parts no.	品名	Description	数量	
					Amt. Req. 1000H	2008H
P 101		M91049089	Tカ`タツキ`テ`	T-shape connector	1	1
P 102		M91035089	サイレンサ`	Muffler	4	4
P 103		MA20A8571	Lカ`タツキ`テ`	L-shape connector	2	2
P 104		MB18E0599	デ`ン`ジ`ベ`ン`ク`ミ`タ`テ`	Solenoid valve assy.	1	1
P 105		M91051089	ミニ`チュ`ア`ゲ`ン`ア`ツ`ベ`ン`	Reducing valve	1	1
P 106	B	M91276004	SW-PW`フ`ラ`マイ`ナ`ベ`ネ`ジ` M4X30`	Screw M4X30`	4	4
P 107		M93201099	ソ`ケ`ツ` PYF-08A`	Socket PYF-08A`	1	1
P 108		M93101099	ホ`ル`ダ`	Relay holder	2	2
P 109		M93005098	リ`レ` MY2-DC24`	Relay MY2-DC24`	1	1
P 110	C	M91059004	SW-PW`フ`ラ`マイ`ナ`ベ`ネ`ジ` M4X12`	Screw M4X12`	2	2
P 111	B	MB62A0757	フ`ラ`グ`	Plug`	2	2
P 112		M91024099	ス`ハ`ク`サ`プ`レ`ッ`サ`コ`ネ`ク`タ` 172006-1`	Diode connector 172006-1`	1	1
P 113		M94004098	ダイ`オ`ド` DSF10TC`	Diode DSF10TC`	1	1
P 114		M97340099	セ`ツ`ゾ`ク`テ`ン`セ`ン`ク`ミ`タ`テ`	Connection wire assy.	1	1
P 115	C	ME18A0508	セ`ツ`ゾ`ク`テ`ン`セ`ン`ク`ミ`タ`テ`	Connection wire assy.	1	1
P 116	C	M97343099	セ`ツ`ゾ`ク`テ`ン`セ`ン`ク`ミ`タ`テ`	Connection wire assy.	2	2
P 117	C	M97344099	セ`ツ`ゾ`ク`テ`ン`セ`ン`ク`ミ`タ`テ`	Connection wire assy.	2	2
P 118		M94001017	セ`フ`テ`ィ`ソ`ケ`ツ` M4X10`	Bolt M4X10`	2	2
P 119		M91067004	SW-PW`フ`ラ`マイ`ナ`ベ`ネ`ジ` M5X10`	Screw M5X10`	3	3
P 120		MB18A0770	ト`ラ`ン`ス`ベ`-`ス`	Transformer base plate	1	1
P 121	B	M91007045	ナ`ツ` M4`	Nut M4`	2	2
P 122		M90511050	サ`カ`ネ` 5`	Washer 5`	4	4
P 123		M95013017	セ`フ`テ`ィ`ソ`ケ`ツ` M5X6`	Bolt M5X6`	4	4
P 124		M818E0TRN	ト`ラ`ン`ス`	Transformer	1	1
P 125		M97339099	セ`ツ`ゾ`ク`テ`ン`セ`ン`ク`ミ`タ`テ`	Connection wire assy.	1	1
P 126		MA20A9571	ワ`ン`タ`ツ`ツ`キ`テ` KJH04-M5`	Connector KJH04-M5`	1	1
P 127	C	M90422050	サ`カ`ネ` 4`	Washer 4`	2	2

Q 付属品(1)  
ACCESSORIES(1)

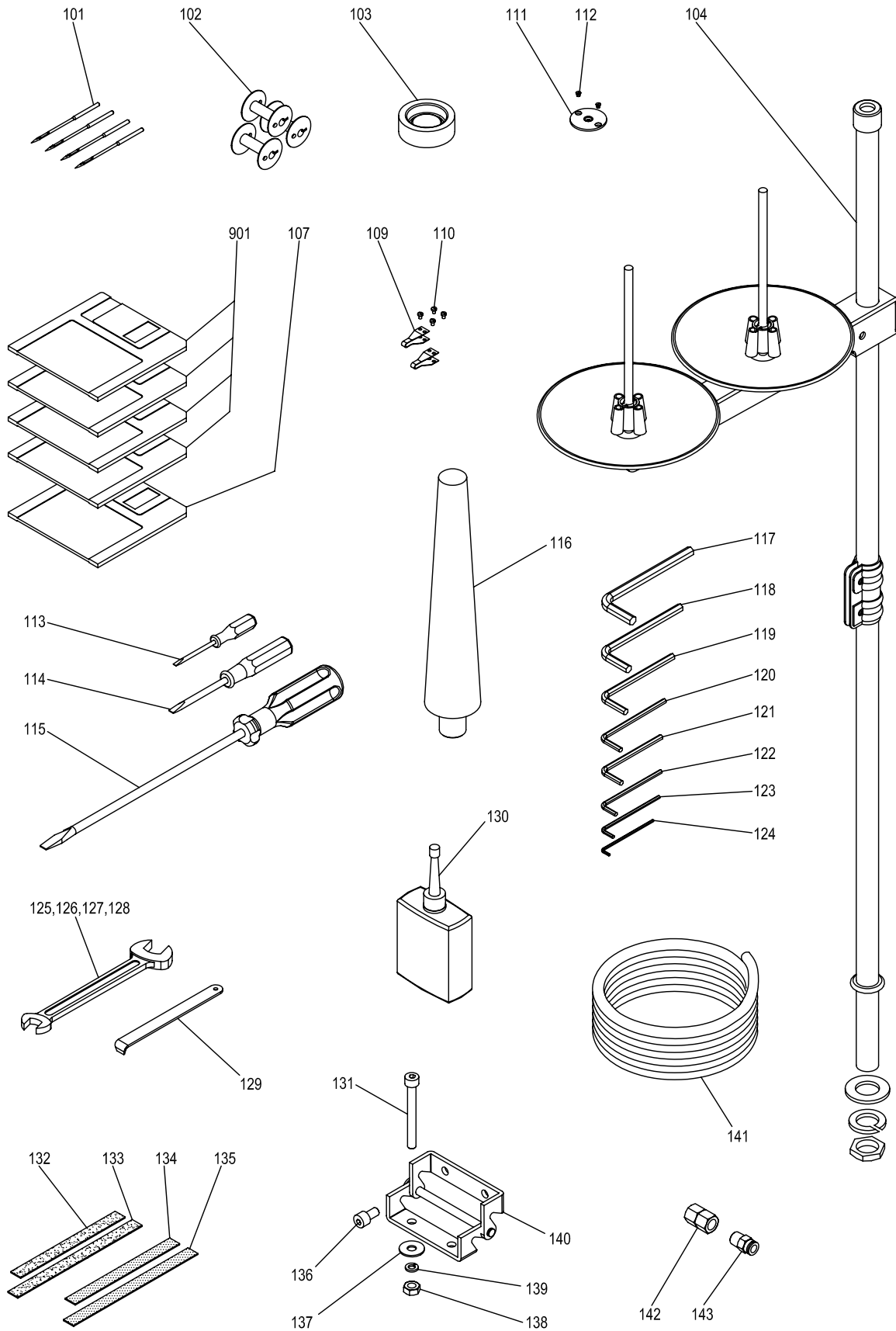

[Q]付属品(1)  
ACCESSORIES(1)

Fig no.	変更 Mod.	部品コード Parts no.	品名	Description	数量	
					Amt. 1000	Req. 2008H
Q 101		MB18A0128	ハリ	Needle	4	4
Q 102		MB18A0123	ホビン	Bobbin	3	3
Q 103		MB60A0419	ホウシゴム	Rubber cushion	6	6
Q 104	C	MF33E0193	イトタダイ	Cotton stand assy.	1	1
Q 107		MB60A1990	フロピイディスク (データ)	Pattern data F/D	1	1
Q 109		MB18A0717	ヒートタイ	Heater	2	2
Q 110		M90672002	ヒラネジ M2X2.8	Screw M2X2.8	4	4
Q 111		MB18A1101	ハリイタ	Needle plate	1	1
Q 112		M90605010	サラネジ 3/32(56)X4	Screw 3/32(56)X4	2	2
Q 113		MB02A1608	ネジマワシ (ショウ)	Screw driver (small)	1	1
Q 114		MB02A0608	ネジマワシ (チュウ)	Screw driver (middle)	1	1
Q 115		MF00A0608	ネジマワシ (ダイ)	Screw driver (large)	1	1
Q 116		MA10A1613	トウフササエ	Head rest	1	1
Q 117		MS05A1976	ロッカクハウスパナ 6	Hexagonal wrench 6	1	1
Q 118		MS05A0976	ロッカクハウスパナ 5	Hexagonal wrench 5	1	1
Q 119		MS01A1976	ロッカクハウスパナ 4	Hexagonal wrench 4	1	1
Q 120		MF90A0976	ロッカクハウスパナ 1/8	Hexagonal wrench 1/8	1	1
Q 121		MS02A2976	ロッカクハウスパナ 3	Hexagonal wrench 3	1	1
Q 122		MS02A1976	ロッカクハウスパナ 2.5	Hexagonal wrench 2.5	1	1
Q 123		MS02A0976	ロッカクハウスパナ 2	Hexagonal wrench 2	1	1
Q 124		MS10A0976	ロッカクハウスパナ 1.5	Hexagonal wrench 1.5	1	1
Q 125		MS02A0479	リョウグチスパナ 13X17	Spanner 13X17	1	1
Q 126		MM10A1479	リョウグチスパナ 14X10	Spanner 14X10	1	1
Q 127		MS10A1976	リョウグチスパナ 8X9	Spanner 8X9	1	1
Q 128		MS10A2976	リョウグチスパナ 6X7	Spanner 6X7	1	1
Q 129		MH00A0610	ドライハーイタ	Driver plate	1	1
Q 130		MF10A0149	アブラサン	Oil container	1	1
Q 131		M96020021	ロッカクアナツキボルト M6X55	Bolt M6X55	4	4
Q 132		MB18A1691	ハッキン (オクリイタヨウ S)	Clamp pad (for feed plate S)	4	4
Q 133		MB18A0691	ハッキン (オクリイタヨウ L)	Clamp pad (for feed plate L)	4	*
Q 133	B	ME28A0691	ハッキン (オクリイタヨウ L)	Clamp pad (for feed plate L)	*	4
Q 134		MB18A3691	ハッキン (ソトオサエヨウ S)	Clamp pad (for clamp frame S)	4	4
Q 135		MB18A2691	ハッキン (ソトオサエヨウ L)	Clamp pad (for clamp frame L)	4	*
Q 135	B	ME28A1691	ハッキン (ソトオサエヨウ L)	Clamp pad (for clamp frame L)	*	4
Q 136		M96002017	セフティソケット M6X12	Bolt M6X12	4	4
Q 137		M90630050	トクシュサガネ (フゾクヨウ)	Flat washer	4	4
Q 138	B	M91576045	ナット M6	Nut M6	4	4
Q 139		M90624053	バネサガネ 6	Spring washer 6	4	4
Q 140		MB60A0560	チョウハン	Hinge	2	2
Q 141	B	MS06A0567	エアチューブ	Air tube	1	1
Q 142		M91010089	ロッカクソケット	Socket	1	1
Q 143		MA30A0571	ワンタッチツギテ	Quick joint	1	1
Q 901	C	ME20E0990	システムフロピイディスク (4マイ)	System F/D (4discs)	1	1

**R** 付属品(2)  
ACCESSORIES(2)

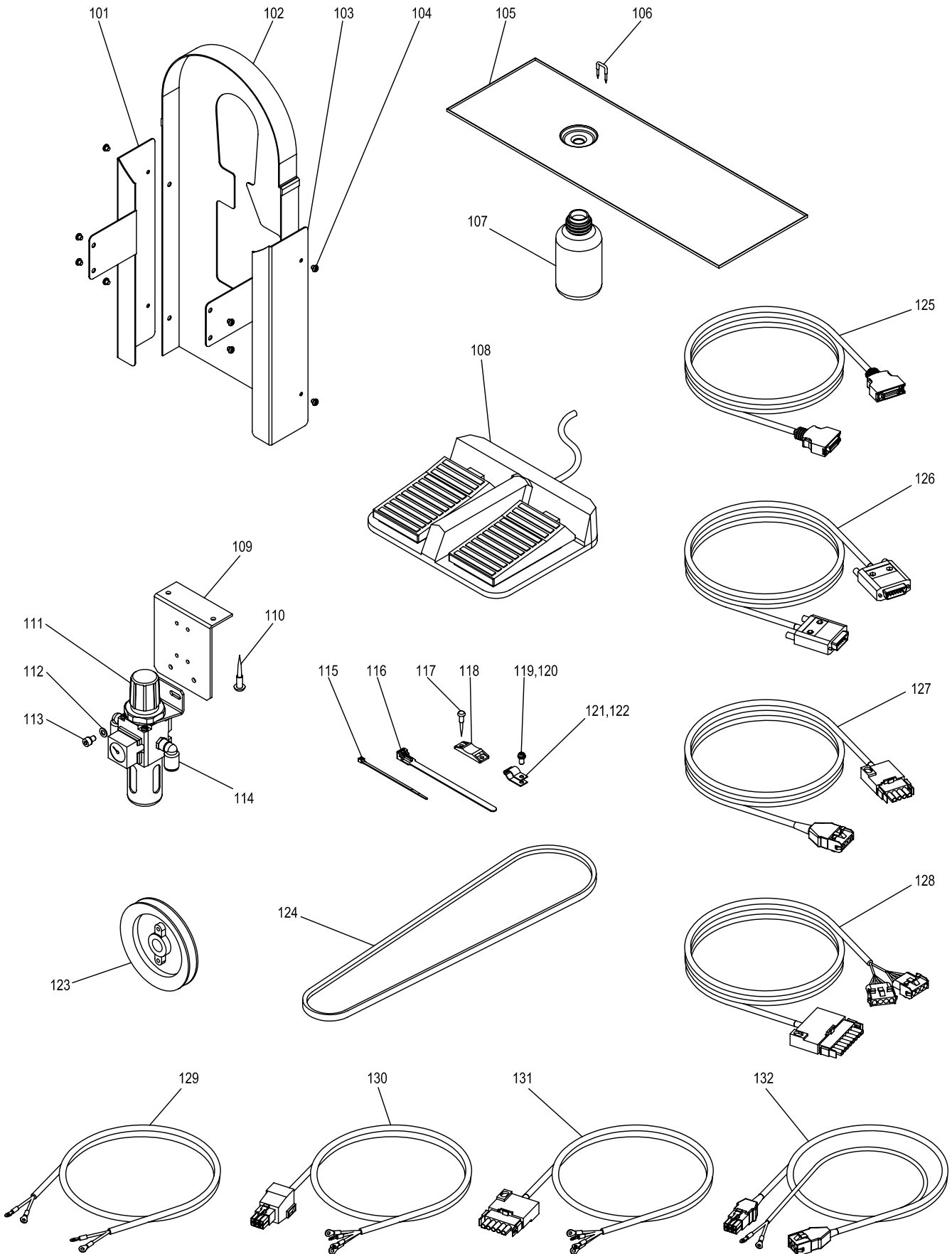

[R] 付属品(2)  
ACCESSORIES(2)

Fig no.	変更 Mod.	部品コード Parts no.	品 名	Description	数量	
					Amt. Req. 1000	Req. 2008
R 101		MB18E1776	ベルトカバー	Belt cover assy.	1	1
R 102		MB18E2776	ベルトカバー	Belt cover assy.	1	1
R 103		MB18E0776	ベルトカバー	Belt cover assy.	1	1
R 104		M91011004	プラマイナヘネジ M4X6	Screw M4X6	8	8
R 105		MB18E0131	アブラウケ	Oil pan	1	1
R 106		M90001043	ステッフル	Staple	12	12
R 107		MF20A0130	アブラビン	Oil bottle	1	1
R 108		M860A0FSW	フットスイッチ	Foot switch	1	1
R 109		MB61A5601	レギュレータトリツケイタ	Filter regulator adapter	1	1
R 110		M90409041	マルモクネジ 4.5X20	Screw 4.5X20	2	2
R 111	C	ME40A0963	フィルタレギュレータ (ステーヅキ)	Filter regulator	1	1
R 112		M90511050	ミカキサガネ 5	Washer 5	2	2
R 113	B	M95003017	セフティソケット M5X8	Bolt M5X8	2	2
R 114		MA20A8571	ワタツツキテ KQL08-01S	Connector KQL08-01S	2	2
R 115		MG51A0201	インシュロックタイ	Cord tie	2	2
R 116		MB60A0201	インシュロックタイ	Cord tie	2	2
R 117		M90306041	マルモクネジ 3.1X16	Wood screw 3.1X16	4	4
R 118		MB60A0420	コテイク	Tie holder	2	2
R 119		M91056004	SW-PWプラマイナヘネジ M4X10	Screw M4X10	1	1
R 120		M90409037	SW-PWツキPナヘネジ M4X10	Screw M4X10	1	1
R 121		MB60A1620	ナイロンクリップ	Nylon clip	1	1
R 122		MB60A2620	ナイロンクリップ	Nylon clip	1	1
R 123		K14MT1000000	プーリ T-100	Pulley T-100	1	1
R 124	B	MB18A1777	Vベルト M55	V-belt M55	1	1
R 125		M97319099	セツクテンセン (ニューリヨクシンゴウ)	Cable (input signal)	1	1
R 126		M97320099	セツクテンセン (ソレノイ)	Cable (output)	1	1
R 127		M97318099	ケーブル (サーボモータ用)	Cable (for servo motor)	1	1
R 128		M97321099	ケーブル (ステッピングモータ)	Cable (stepping motor)	1	1
R 129		M97349099	ケーブル (ステッピングモータ)	Cable (stepping motor)	(*1)	(*1)
R 130		M97350099	ケーブル (ステッピングモータ)	Cable (stepping motor)	(*2)	(*2)
R 131		M97351099	ケーブル (ステッピングモータ)	Cable (stepping motor)	(*3)	(*3)
R 132		M97345099	ケーブル (ステッピングモータ)	Cable (stepping motor)	(*4)	(*4)

(\*1)~(\*4) パーツナンバー Q131~Q132は、ご使用地域とご使用電源により付属形態が異なります。

For part No.R131-R132, attached form is different according to the region and power supply

ご使用地域	EC諸国を除く地域	EC諸国	
Region	except EC	EC nations	
電源 Power supply	全て ALL	1φ 220V	3φ 380V
R129	-	-	1
R130	-	-	1
R131	-	1	1
R132	1	-	-

索引  
INDEX-1

部品コード Parts No.	ページ Page	Fig No.	部品コード Parts No.	ページ Page	Fig No.	部品コード Parts No.	ページ Page	Fig No.	部品コード Parts No.	ページ Page	Fig No.
K14MT1000000	*** P31	*** R 123	M90672002	*** P13	*** G 143	M91116001	*** P19	*** K 123	M91802035	*** P9	*** E 154
M800E2CON	*** P25	*** N 129	M90804065	*** P5	*** C 106	M91119002	*** P21	*** L 155	M91803022	*** P3	*** B 115
M818E0TRN	*** P27	*** P 124	M90806002	*** P11	*** F 130	M91119011	*** P7	*** D 106	M91807045	*** P5	*** C 103
M860A0FSW	*** P31	*** R 108	M90806003	*** P19	*** K 132	M91129003	*** P17	*** J 105	↑	*** P5	*** C 138
M90001043	*** P31	*** R 106	M90807003	*** P19	*** K 117	↑	*** P19	*** K 115	M91808045	*** P9	*** E 155
M90118099	*** P25	*** N 101	M90808065	*** P9	*** E 140	M91131015	*** P23	*** M 114	↑	*** P17	*** J 123
M90301017	*** P9	*** E 151	M90823050	*** P3	*** B 116	M91140002	*** P5	*** C 120	↑	*** P19	*** K 108
M90301080	*** P7	*** D 110	M90824002	*** P19	*** K 106	M91142003	*** P19	*** K 127	↑	*** P7	*** D 118
M90305064	*** P9	*** E 125	M90831050	*** P9	*** E 149	M91143003	*** P19	*** K 111	M91910080	*** P3	*** B 154
M90306041	*** P31	*** R 117	M90854045	*** P9	*** E 167	M91144003	*** P19	*** K 105	M92003015	*** P9	*** E 163
M90316050	*** P15	*** H 115	M90855045	*** P19	*** K 133	M91145015	*** P19	*** K 131	M92004015	*** P5	*** C 102
↑	*** P13	*** G 123	M90859004	*** P21	*** L 104	M91183080	*** P3	*** B 155	M92005022	*** P5	*** C 118
M90322063	*** P15	*** H 101	↑	*** P21	*** L 107	M91207045	*** P19	*** K 126	M92006022	*** P9	*** E 148
M90323063	*** P17	*** J 127	M90875045	*** P15	*** H 116	M91209001	*** P7	*** D 131	M92055003	*** P5	*** C 117
↑	*** P11	*** F 111	↑	*** P11	*** F 106	M91252003	*** P9	*** E 126	M92075045	*** P23	*** M 121
M90329060	*** P17	*** J 113	↑	*** P13	*** G 136	M91253003	*** P7	*** D 139	↑	*** P3	*** B 121
M90331060	*** P7	*** D 153	M90883080	*** P3	*** B 134	M91254045	*** P3	*** B 149	M93001020	*** P23	*** M 108
M90331065	*** P17	*** J 119	M90906003	*** P3	*** B 137	M91276004	*** P27	*** P 106	M93005098	*** P27	*** P 109
M90357037	*** P3	*** B 109	↑	*** P3	*** B 131	↑	*** P11	*** F 104	M93015021	*** P7	*** D 136
M90358037	*** P11	*** F 131	M90922002	*** P11	*** F 114	M91330004	*** P3	*** B 147	M93101099	*** P27	*** P 108
M90359037	*** P15	*** H 108	M90947003	*** P17	*** J 142	M91382045	*** P13	*** G 127	M93201099	*** P27	*** P 107
↑	*** P13	*** G 144	M90948003	*** P17	*** J 114	M91404017	*** P3	*** B 145	M93301045	*** P9	*** E 147
M90361037	*** P3	*** B 125	↑	*** P17	*** J 106	M91405017	*** P3	*** B 146	M94001017	*** P11	*** F 134
M90409037	*** P31	*** R 120	↑	*** P19	*** K 118	M91505002	*** P7	*** D 156	↑	*** P21	*** L 147
M90409041	*** P31	*** R 110	M90971004	*** P25	*** N 113	M91508045	*** P17	*** J 135	↑	*** P25	*** N 119
M90421050	*** P11	*** F 133	M90990002	*** P3	*** B 130	M91509003	*** P19	*** K 121	↑	*** P27	*** P 118
↑	*** P15	*** H 117	M91007045	*** P7	*** D 146	M91510003	*** P9	*** E 105	M94001030	*** P3	*** B 132
↑	*** P23	*** M 136	↑	*** P27	*** P 121	M91511003	*** P17	*** J 108	M94002017	*** P13	*** G 106
↑	*** P13	*** G 147	M91010089	*** P29	*** Q 142	↑	*** P9	*** E 161	↑	*** P23	*** M 123
M90422050	*** P27	*** P 127	M91011004	*** P31	*** R 104	M91523001	*** P5	*** C 119	↑	*** P23	*** M 103
M90446037	*** P13	*** G 129	M91012004	*** P7	*** D 147	↑	*** P7	*** D 101	↑	*** P3	*** B 119
M90455050	*** P19	*** K 129	M91024099	*** P27	*** P 112	M91524001	*** P5	*** C 132	M94003017	*** P13	*** G 121
M90503045	*** P17	*** J 110	M91025099	*** P25	*** N 125	M91524002	*** P5	*** C 131	↑	*** P21	*** L 119
M90504065	*** P23	*** M 118	M91035089	*** P27	*** P 102	M91525001	*** P19	*** K 110	M94003099	*** P25	*** N 112
↑	*** P13	*** G 101	M91049089	*** P27	*** P 101	↑	*** P7	*** D 122	M94004017	*** P13	*** G 119
↑	*** P15	*** H 105	M91051089	*** P27	*** P 105	↑	*** P9	*** E 143	M94004098	*** P27	*** P 113
M90511050	*** P31	*** R 112	M91053020	*** P23	*** M 126	M91525002	*** P9	*** E 107	M94005017	*** P13	*** G 124
↑	*** P27	*** P 122	M91054004	*** P25	*** N 107	M91526001	*** P7	*** D 137	↑	*** P21	*** L 120
↑	*** P13	*** G 114	M91056004	*** P31	*** R 119	M91528015	*** P9	*** E 101	M94005037	*** P3	*** B 122
↑	*** P21	*** L 153	M91057004	*** P25	*** N 126	M91576045	*** P29	*** Q 138	↑	*** P23	*** M 104
M90511065	*** P13	*** G 108	M91058004	*** P3	*** B 101	M91600010	*** P5	*** C 135	M94006017	*** P23	*** M 129
M90512050	*** P23	*** M 137	↑	*** P21	*** L 112	M91606022	*** P25	*** N 117	↑	*** P21	*** L 116
M90512065	*** P23	*** M 111	↑	*** P25	*** N 102	M91608022	*** P11	*** F 103	M94006021	*** P7	*** D 145
M90516065	*** P21	*** L 152	M91058020	*** P15	*** H 103	M91612046	*** P19	*** K 101	M94008017	*** P11	*** F 105
M90518050	*** P15	*** H 126	M91059004	*** P27	*** P 110	↑	*** P17	*** J 101	↑	*** P15	*** H 118
M90573080	*** P3	*** B 133	↑	*** P3	*** B 108	M91633001	*** P5	*** C 130	M94012017	*** P21	*** L 122
M90604065	*** P21	*** L 136	M91067004	*** P3	*** B 105	↑	*** P9	*** E 130	M94013017	*** P13	*** G 103
M90605010	*** P29	*** Q 112	↑	*** P27	*** P 119	M91634001	*** P5	*** C 133	M94014017	*** P17	*** J 124
↑	*** P3	*** B 141	M91071004	*** P3	*** B 103	↑	*** P9	*** E 135	M94019017	*** P7	*** D 151
M90608003	*** P19	*** K 136	↑	*** P21	*** L 124	M91635001	*** P5	*** C 111	M94021017	*** P15	*** H 107
M90624053	*** P29	*** Q 139	M91103017	*** P7	*** D 140	↑	*** P7	*** D 121	M94022017	*** P15	*** H 120
↑	*** P21	*** L 145	M91107022	*** P5	*** C 127	↑	*** P9	*** E 152	M94026017	*** P7	*** D 148
M90630050	*** P29	*** Q 137	M91111015	*** P19	*** K 135	M91650020	*** P13	*** G 112	M95001017	*** P21	*** L 151
M90672002	*** P15	*** H 109	M91111045	*** P7	*** D 112	M91701015	*** P9	*** E 166	M95002017	*** P11	*** F 112
↑	*** P29	*** Q 110	M91112045	*** P19	*** K 125	M91770015	*** P17	*** J 118	↑	*** P9	*** E 132

索引  
INDEX-2

部品コード Parts No.	ページ Page	Fig No.	部品コード Parts No.	ページ Page	Fig No.	部品コード Parts No.	ページ Page	Fig No.	部品コード Parts No.	ページ Page	Fig No.
M95002017	*** P11	*** F 112	MA21P0750	*** P13	*** G 104	MB18A0287	*** P9	*** E 146	MB18A0750	*** P15	*** H 124
↑	*** P13	*** G 125	MA30A0422	*** P13	*** G 135	MB18A0293	*** P9	*** E 158	MB18A0751	*** P23	*** M 122
M95003017	*** P3	*** B 114	MA30A0571	*** P29	*** Q 143	MB18A0325	*** P7	*** D 117	MB18A0756	*** P7	*** D 109
↑	*** P23	*** M 132	MA30A0758	*** P21	*** L 125	MB18A0327	*** P7	*** D 105	MB18A0757	*** P7	*** D 115
↑	*** P31	*** R 113	MA35A1781	*** P21	*** L 133	MB18A0339	*** P3	*** B 123	MB18A0770	*** P27	*** P 120
M95004017	*** P21	*** L 126	MA35A6758	*** P21	*** L 138	MB18A0350	*** P7	*** D 102	MB18A0784	*** P9	*** E 169
M95005017	*** P15	*** H 123	MA45A5758	*** P21	*** L 154	MB18A0352	*** P19	*** K 141	MB18A0797	*** P3	*** B 129
M95005017	*** P25	*** N 111	MB02A0608	*** P29	*** Q 114	MB18A0390	*** P21	*** L 142	MB18A0802	*** P13	*** G 120
M95006021	*** P13	*** G 116	MB02A1608	*** P29	*** Q 113	MB18A0407	*** P21	*** L 114	MB18A0803	*** P19	*** K 114
M95011021	*** P21	*** L 137	MB18A0101	*** P3	*** B 140	MB18A0411	*** P5	*** C 105	MB18A0830	*** P3	*** B 142
M95013017	*** P27	*** P 123	MB18A0120	*** P7	*** D 133	MB18A0412	*** P5	*** C 104	MB18A0833	*** P7	*** D 123
M95014021	*** P13	*** G 128	MB18A0121	*** P7	*** D 129	MB18A0434	*** P23	*** M 117	MB18A0912	*** P9	*** E 106
M95043095	*** P21	*** L 140	MB18A0123	*** P7	*** D 128	MB18A0450	*** P7	*** D 126	MB18A0914	*** P7	*** D 103
M95051021	*** P23	*** M 115	↑	*** P29	*** Q 102	MB18A0451	*** P7	*** D 125	MB18A0921	*** P21	*** L 157
M95056095	*** P21	*** L 132	MB18A0128	*** P5	*** C 128	MB18A0452	*** P7	*** D 120	MB18A0950	*** P23	*** M 112
M96002001	*** P21	*** L 129	↑	*** P29	*** Q 101	MB18A0454	*** P7	*** D 113	MB18A0955	*** P7	*** D 114
M96002017	*** P29	*** Q 136	MB18A0132	*** P3	*** B 110	MB18A0456	*** P5	*** C 112	MB18A0973	*** P9	*** E 124
M96020021	*** P29	*** Q 131	MB18A0150	*** P13	*** G 126	MB18A0458	*** P21	*** L 110	MB18A0980	*** P11	*** F 113
M96030021	*** P9	*** E 142	MB18A0154	*** P7	*** D 135	MB18A0461	*** P9	*** E 153	MB18A1101	*** P29	*** Q 111
M96031021	*** P7	*** D 143	MB18A0155	*** P19	*** K 107	MB18A0462	*** P9	*** E 168	MB18A1154	*** P13	*** G 117
M96032021	*** P9	*** E 109	MB18A0157	*** P3	*** B 150	MB18A0470	*** P3	*** B 128	MB18A1157	*** P13	*** G 102
M96061021	*** P21	*** L 144	MB18A0160	*** P11	*** F 125	MB18A0476	*** P19	*** K 113	MB18A1187	*** P17	*** J 136
M96101099	*** P13	*** G 137	MB18A0175	*** P17	*** J 132	MB18A0477	*** P21	*** L 106	MB18A1191	*** P19	*** K 139
↑	*** P15	*** H 114	MB18A0180	*** P17	*** J 115	MB18A0523	*** P21	*** L 149	MB18A1192	*** P19	*** K 137
M96201099	*** P13	*** G 141	MB18A0181	*** P19	*** K 119	MB18A0551	*** P19	*** K 142	MB18A1194	*** P19	*** K 122
↑	*** P15	*** H 111	MB18A0187	*** P17	*** J 134	MB18A0555	*** P17	*** J 103	MB18A1196	*** P19	*** K 116
M96301099	*** P13	*** G 140	MB18A0189	*** P19	*** K 128	↑	*** P19	*** K 103	MB18A1213	*** P17	*** J 133
M97313099	*** P25	*** N 104	MB18A0190	*** P19	*** K 112	MB18A0557	*** P9	*** E 156	MB18A1216	*** P11	*** F 120
M97318099	*** P31	*** R 127	MB18A0191	*** P19	*** K 138	MB18A0571	*** P13	*** G 134	MB18A1254	*** P9	*** E 108
M97319099	*** P31	*** R 125	MB18A0192	*** P17	*** J 102	MB18A0572	*** P7	*** D 132	MB18A1257	*** P17	*** J 130
M97320099	*** P31	*** R 126	MB18A0194	*** P19	*** K 109	MB18A0581	*** P5	*** C 107	MB18A1259	*** P17	*** J 107
M97321099	*** P31	*** R 128	MB18A0200	*** P13	*** G 111	MB18A0582	*** P5	*** C 101	MB18A1261	*** P9	*** E 121
M97335099	*** P25	*** N 105	MB18A0211	*** P17	*** J 116	MB18A0584	*** P3	*** B 143	MB18A1263	*** P23	*** M 107
M97336099	*** P25	*** N 106	MB18A0213	*** P17	*** J 104	MB18A0590	*** P9	*** E 162	MB18A1265	*** P9	*** E 129
M97339099	*** P27	*** P 125	↑	*** P19	*** K 104	MB18A0601	*** P13	*** G 142	MB18A1293	*** P9	*** E 150
M97340099	*** P27	*** P 114	MB18A0216	*** P17	*** J 137	↑	*** P15	*** H 113	MB18A1339	*** P3	*** B 124
M97341099	*** P25	*** N 124	MB18A0221	*** P17	*** J 117	MB18A0603	*** P9	*** E 157	MB18A1390	*** P23	*** M 124
M97343099	*** P13	*** G 146	MB18A0223	*** P17	*** J 120	MB18A0611	*** P7	*** D 127	MB18A1411	*** P5	*** C 105
↑	*** P15	*** H 119	MB18A0231	*** P5	*** C 109	MB18A0621	*** P15	*** H 127	MB18A1412	*** P7	*** D 116
↑	*** P27	*** P 116	MB18A0232	*** P9	*** E 144	MB18A0660	*** P5	*** C 124	MB18A1434	*** P13	*** G 133
M97344099	*** P13	*** G 145	MB18A0233	*** P5	*** C 114	MB18A0661	*** P5	*** C 137	MB18A1454	*** P9	*** E 128
↑	*** P15	*** H 122	MB18A0234	*** P5	*** C 113	MB18A0662	*** P5	*** C 134	MB18A1476	*** P21	*** L 118
↑	*** P27	*** P 117	MB18A0251	*** P3	*** B 148	MB18A0663	*** P5	*** C 123	MB18A1477	*** P21	*** L 102
M97345099	*** P31	*** R 132	MB18A0252	*** P23	*** M 110	MB18A0664	*** P5	*** C 126	MB18A1481	*** P23	*** M 135
M97349099	*** P31	*** R 129	MB18A0254	*** P9	*** E 127	MB18A0665	*** P5	*** C 125	MB18A1523	*** P21	*** L 127
M97350099	*** P31	*** R 130	MB18A0256	*** P9	*** E 133	MB18A0688	*** P7	*** D 111	MB18A1571	*** P21	*** L 131
M97351099	*** P31	*** R 131	MB18A0257	*** P9	*** E 160	MB18A0691	*** P29	*** Q 133	↑	*** P21	*** L 141
M98005017	*** P9	*** E 103	MB18A0259	*** P9	*** E 122	MB18A0700	*** P19	*** K 130	MB18A1603	*** P17	*** J 126
M98014021	*** P7	*** D 107	MB18A0261	*** P9	*** E 120	MB18A0702	*** P9	*** E 165	MB18A1664	*** P9	*** E 131
MA10A1613	*** P29	*** Q 116	MB18A0262	*** P9	*** E 134	MB18A0717	*** P13	*** G 139	MB18A1691	*** P29	*** Q 132
MA20A0257	*** P21	*** L 109	MB18A0263	*** P23	*** M 130	↑	*** P15	*** H 110	MB18A1700	*** P19	*** K 140
MA20A8571	*** P27	*** P 103	MB18A0265	*** P9	*** E 123	↑	*** P29	*** Q 109	MB18A1702	*** P17	*** J 138
↑	*** P31	*** R 114	MB18A0274	*** P9	*** E 141	MB18A0725	*** P9	*** E 102	MB18A1740	*** P17	*** J 131
MA20A9571	*** P27	*** P 126	MB18A0275	*** P9	*** E 170	MB18A0740	*** P5	*** C 110	MB18A1742	*** P3	*** B 107
MA21P0454	*** P21	*** L 135	MB18A0284	*** P9	*** E 145	MB18A0742	*** P7	*** D 130	MB18A1777	*** P31	*** R 124

索引  
INDEX-3

部品コード Parts No.	ページ Page	Fig No.	部品コード Parts No.	ページ Page	Fig No.	部品コード Parts No.	ページ Page	Fig No.	部品コード Parts No.	ページ Page	Fig No.
MB18A1784	*** P9	*** E 110	MB18B1601	*** P3	*** B 118	MB18M9601	*** P13	*** G 107	ME28A0470	*** P3	*** B 128
MB18A1833	*** P7	*** D 108	MB18B2454	*** P17	*** J 121	MB45A0767	*** P21	*** L 128	ME28A0691	*** P29	*** Q 133
MB18A1910	*** P9	*** E 164	MB18B2601	*** P11	*** F 115	MB48A0486	*** P25	*** N 103	ME28A0797	*** P3	*** B 129
MB18A1921	*** P21	*** L 156	MB18B3601	*** P21	*** L 111	MB60A0201	*** P31	*** R 116	ME28A0920	*** P21	*** L 121
MB18A1950	*** P23	*** M 128	MB18B4454	*** P13	*** G 105	MB60A0366	*** P25	*** N 127	ME28A1272	*** P23	*** M 133
MB18A1955	*** P7	*** D 104	MB18B4601	*** P21	*** L 108	MB60A0419	*** P29	*** Q 103	ME28A1339	*** P3	*** B 124
MB18A2138	*** P17	*** J 112	MB18B5454	*** P13	*** G 110	MB60A0420	*** P31	*** R 118	ME28A1691	*** P29	*** Q 135
MB18A2180	*** P17	*** J 141	MB18B5601	*** P21	*** L 113	MB60A0560	*** P29	*** Q 140	ME28E0339	*** P3	*** B 126
MB18A2194	*** P19	*** K 124	MB18B6601	*** P15	*** H 106	MB60A0601	*** P11	*** F 129	ME28E0957	*** P21	*** L 117
MB18A2339	*** P25	*** N 116	MB18B7601	*** P7	*** D 142	MB60A0750	*** P3	*** B 120	ME28E1339	*** P3	*** B 127
MB18A2390	*** P21	*** L 130	MB18B8601	*** P7	*** D 141	MB60A0915	*** P25	*** N 108	ME40A0963	*** P31	*** R 111
MB18A2411	*** P5	*** C 105	MB18C0601	*** P13	*** G 109	MB60A1620	*** P31	*** R 121	MF00A0608	*** P29	*** Q 115
MB18A2476	*** P3	*** B 112	MB18C1601	*** P13	*** G 122	MB60A1990	*** P29	*** Q 107	MF10A0149	*** P29	*** Q 130
MB18A2477	*** P21	*** L 101	MB18C2601	*** P11	*** F 102	MB60A2352	*** P25	*** N 128	MF20A0130	*** P31	*** R 107
MB18A2571	*** P21	*** L 131	MB18C3601	*** P11	*** F 119	MB60A2620	*** P31	*** R 122	MF33E0193	*** P29	*** Q 104
MB18A2601	*** P13	*** G 138	MB18E0131	*** P31	*** R 105	MB60A5601	*** P25	*** N 123	MF90A0976	*** P29	*** Q 120
↑	*** P15	*** H 121	MB18E0138	*** P17	*** J 901	MB60A5780	*** P25	*** N 121	MG51A0201	*** P31	*** R 115
MB18A2603	*** P19	*** K 120	MB18E0139	*** P3	*** B 111	MB60A6780	*** P25	*** N 122	MH00A0610	*** P29	*** Q 129
MB18A2691	*** P29	*** Q 135	MB18E0155	*** P19	*** K 901	MB61A0650	*** P3	*** B 136	MM10A1479	*** P29	*** Q 126
MB18A2740	*** P7	*** D 138	MB18E0190	*** P19	*** K 902	MB61A5601	*** P31	*** R 109	MS01A0361	*** P3	*** B 135
MB18A2742	*** P23	*** M 105	MB18E0199	*** P13	*** G 903	MB62A0757	*** P27	*** P 111	MS01A0477	*** P11	*** F 126
MB18A2910	*** P9	*** E 159	MB18E0339	*** P3	*** B 127	MB62A0767	*** P21	*** L 134	MS01A1739	*** P11	*** F 124
MB18A3138	*** P17	*** J 109	MB18E0406	*** P25	*** N 109	MB62A0921	*** P23	*** M 127	MS01A1976	*** P29	*** Q 119
MB18A3180	*** P5	*** C 129	MB18E0436	*** P15	*** H 125	MB62A0975	*** P23	*** M 116	MS02A0479	*** P29	*** Q 125
MB18A3257	*** P23	*** M 134	MB18E0450	*** P7	*** D 901	ME10A0154	*** P7	*** D 152	MS02A0976	*** P29	*** Q 123
MB18A3477	*** P11	*** F 107	MB18E0455	*** P23	*** M 125	ME10A0408	*** P25	*** N 115	MS02A1976	*** P29	*** Q 122
MB18A3601	*** P25	*** N 110	MB18E0599	*** P27	*** P 104	ME10A0484	*** P25	*** N 901	MS02A2456	*** P21	*** L 123
MB18A3603	*** P15	*** H 112	MB18E0682	*** P5	*** C 902	ME10A0705	*** P7	*** D 149	MS02A2976	*** P29	*** Q 121
MB18A3621	*** P11	*** F 110	MB18E0742	*** P3	*** B 106	ME10E0484	*** P25	*** N 114	MS05A0976	*** P29	*** Q 118
↑	*** P17	*** J 122	MB18E0776	*** P31	*** R 103	ME10E1484	*** P25	*** N 118	MS05A1976	*** P29	*** Q 117
MB18A3691	*** P29	*** Q 134	MB18E0778	*** P21	*** L 143	ME18A0230	*** P5	*** C 108	MS06A0567	*** P29	*** Q 141
MB18A3740	*** P7	*** D 119	MB18E0781	*** P21	*** L 146	ME18A0272	*** P23	*** M 133	MS07A0740	*** P5	*** C 140
MB18A3920	*** P21	*** L 121	MB18E0802	*** P3	*** B 113	ME18A0300	*** P7	*** D 154	MS10A0192	*** P3	*** B 139
MB18A4180	*** P17	*** J 111	MB18E0982	*** P11	*** F 903	ME18A0339	*** P11	*** F 108	MS10A0976	*** P29	*** Q 124
MB18A4339	*** P5	*** C 121	MB18E1180	*** P17	*** J 903	ME18A0408	*** P25	*** N 120	MS10A1456	*** P3	*** B 117
MB18A4454	*** P23	*** M 119	MB18E1339	*** P3	*** B 126	ME18A0454	*** P7	*** D 155	MS10A1976	*** P29	*** Q 127
MB18A4601	*** P21	*** L 115	MB18E1717	*** P15	*** H 902	ME18A0454	*** P23	*** M 113	MS10A2976	*** P29	*** Q 128
MB18A4603	*** P13	*** G 113	MB18E1776	*** P31	*** R 101	ME18A0508	*** P27	*** P 115	MS13A0758	*** P21	*** L 150
MB18A4910	*** P9	*** E 111	MB18E1957	*** P21	*** L 117	ME18A0572	*** P7	*** D 150	MS13A2454	*** P21	*** L 148
MB18A4920	*** P21	*** L 103	MB18E2339	*** P3	*** B 104	ME18A0740	*** P3	*** B 153			
MB18A5192	*** P19	*** K 134	MB18E2776	*** P31	*** R 102	ME18A0756	*** P7	*** D 109			
MB18A5454	*** P23	*** M 109	MB18E4339	*** P3	*** B 138	ME18A0780	*** P3	*** B 151			
MB18A5603	*** P13	*** G 115	MB18E8434	*** P13	*** G 902	ME18A0950	*** P7	*** D 144			
MB18A5910	*** P17	*** J 129	MB18E8501	*** P13	*** G 118	ME18A0955	*** P7	*** D 104			
MB18A6192	*** P19	*** K 102	MB18E9501	*** P11	*** F 101	ME18A0957	*** P21	*** L 105			
MB18A6454	*** P5	*** C 136	MB18F0434	*** P11	*** F 901	ME18A0982	*** P11	*** F 116			
MB18A7339	*** P5	*** C 122	MB18F0501	*** P11	*** F 109	ME18A1339	*** P13	*** G 130			
MB18A7454	*** P5	*** C 139	MB18F1434	*** P11	*** F 902	ME18E1230	*** P5	*** C 901			
MB18A8454	*** P7	*** D 134	MB18F1501	*** P15	*** H 102	ME20E0990	*** P29	*** Q 901			
MB18A9339	*** P3	*** B 102	MB18F2434	*** P15	*** H 901	ME28A0257	*** P23	*** M 134			
MB18A9454	*** P7	*** D 124	MB18F2501	*** P9	*** E 104	ME28A0339	*** P3	*** B 123			
MB18B0339	*** P11	*** F 118	MB18F3434	*** P9	*** E 901	ME28A0390	*** P21	*** L 130			
MB18B0454	*** P15	*** H 104	MB18F3501	*** P17	*** J 125	ME28A0407	*** P21	*** L 114			
MB18B1339	*** P11	*** F 117	MB18F4434	*** P13	*** G 901	ME28A0454	*** P23	*** M 120			
MB18B1454	*** P23	*** M 120	MB18F5434	*** P17	*** J 902	ME28A0455	*** P23	*** M 125			

 三菱電機株式会社

 MITSUBISHI ELECTRIC CORPORATION

---