

**81200CZ123**  
**ADJUSTMENTS AND PARTS**  
**SUPPLEMENT**

CATALOG NO. K74715

SP457-2271  
05/21/04

**THREADING DIAGRAM  
FOR 81200CZ123**

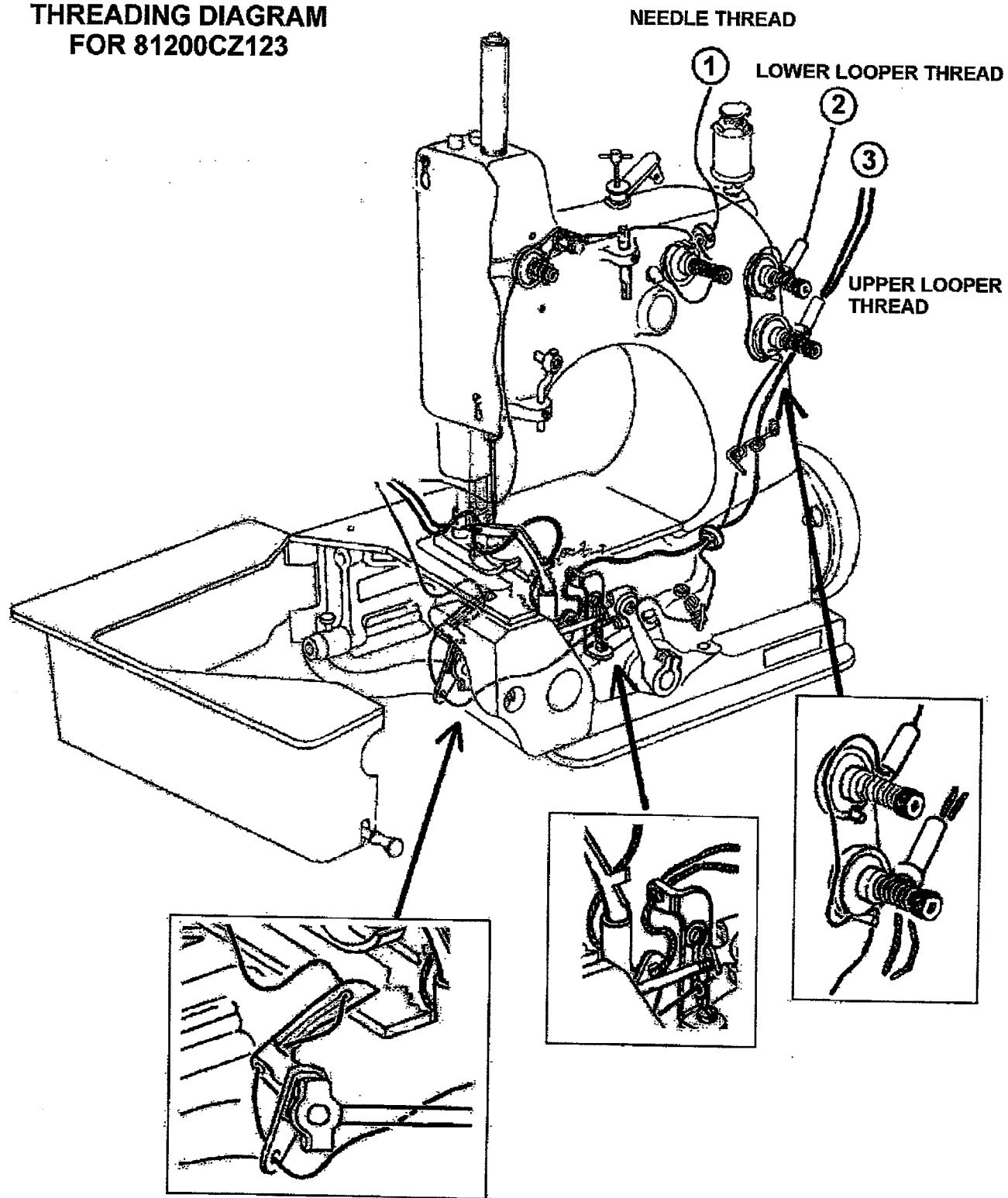

# 81200CZ123

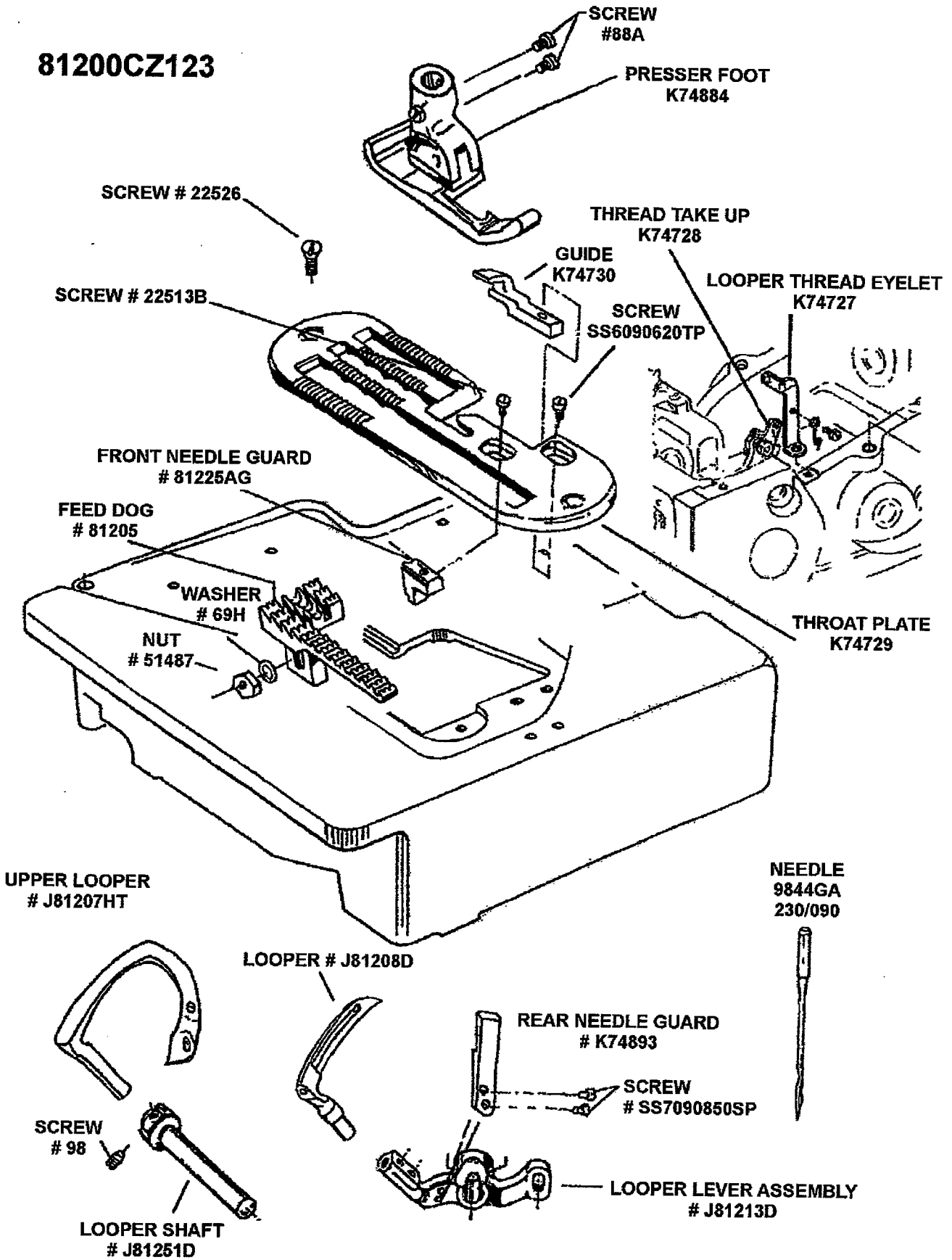

## ADJUSTING INSTRUCTIONS

### SETTING THE NEEDLE

Before adjusting the machine, insert a new needle into the needle bar as far as possible. The long groove of the needle must be directed to the operator. Tighten the needle clamp nut securely.

### ADJUSTING THE LOOPER

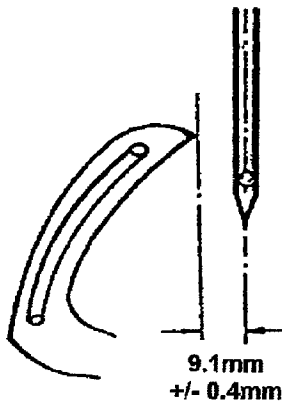

Fig. 1

For convenient access, remove the presser foot, throat plate and feed dog. Insert the looper into the looper rocker. Set the looper so that the distance from the centre line of the needle to the point of the looper is 9.1 mm (23 / 64") in the lowest position of needle bar just before moving upwards (Fig. 1). Therefore loosen the nut at right side of looper rocker and replace the ball stud till the specified dimension be obtained. As the looper moves to the right, its point should pass behind the needle as close as possible without contacting it. Adjustment can be made by loosening the fastening screws of looper rocker and replacing the looper rocker axially till this adjustment be obtained.

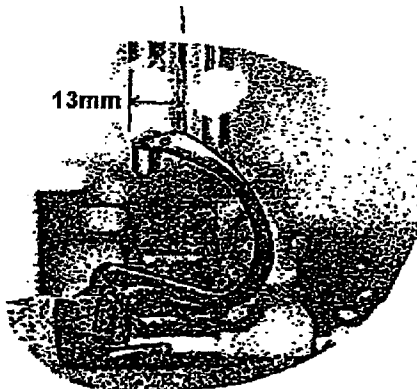

Fig. 2

### ADJUSTING THE UPPER LOOPER

The spreader should closely pass behind the looper and behind the needle so that its point just brushes, without deflecting them. Set the distance of 13mm  $\pm$  1mm (1/2"  $\pm$  1/32") between looper top and center of needle (Fig. 2).

NOTE : If adjustment front or back is necessary, loosen two screw ( A ) Fig.3, and move spreader as required. Re-tighten two screws after adjustment.

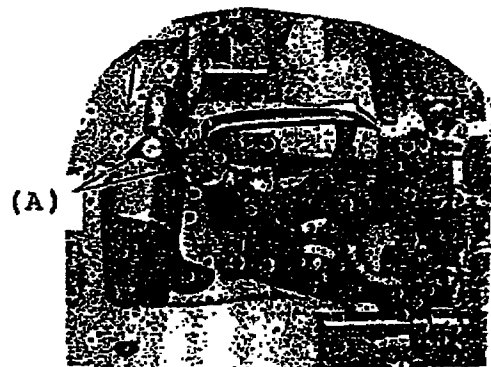

Fig.3

#### SETTING THE NEEDLE BAR HEIGHT

Set the needle bar so that the top of the needle eye is even with the underside of the looper, when the looper point in its travel to the right projects 1-1.5 mm = 0.04-0.06" from the right side of the needle. If adjustment is necessary loosen the clamping screw in the needle bar connection and move the needle bar up or down as required and retighten the screw.

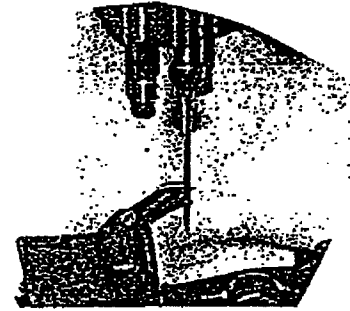

Fig. 4

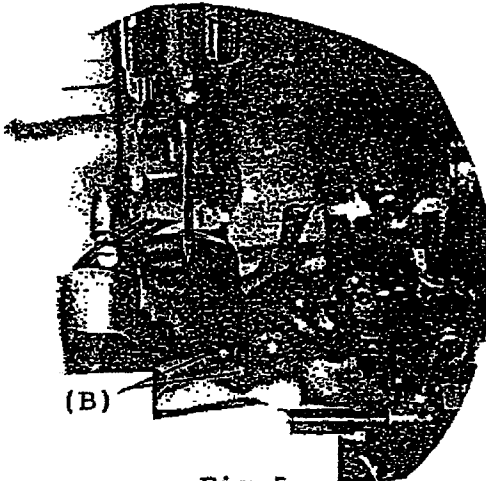

Fig. 5

#### SETTING THE REAR NEEDLE GUARD

Set the rear needle guard ( Looper lever needle guard ) so that it barely contacts the needle when the looper point approaches the left side of needle. Adjustment can be made by loosening the two screws (B) / Fig. 5 and re-set the needle guard at proper position.

NOTE: Change in stitch length will not require change in needle guard, but a change of needle size may require.

#### ADJUSTING THE FEED DOG

The height of the feed dog is correct, when at its highest point of travel, the rear teeth project above the throat plate their full depth. This can be accomplished by removing the feed dog holding screw and feed dog, then adjusting the stop screw in feed bar as required to maintain the prescribed setting. To adjust the feed dog within the throat plate, loosen the 2 bottom screws of the feed rocker and after adjusting as required retighten them.

#### NEEDLE THREAD TAKE UP

The setting of the needle thread take-up is correct when the needle thread is raised about 2 - 3 mm = 5/64 - 1/8" while the needle is descending.

**INSTALLATION**

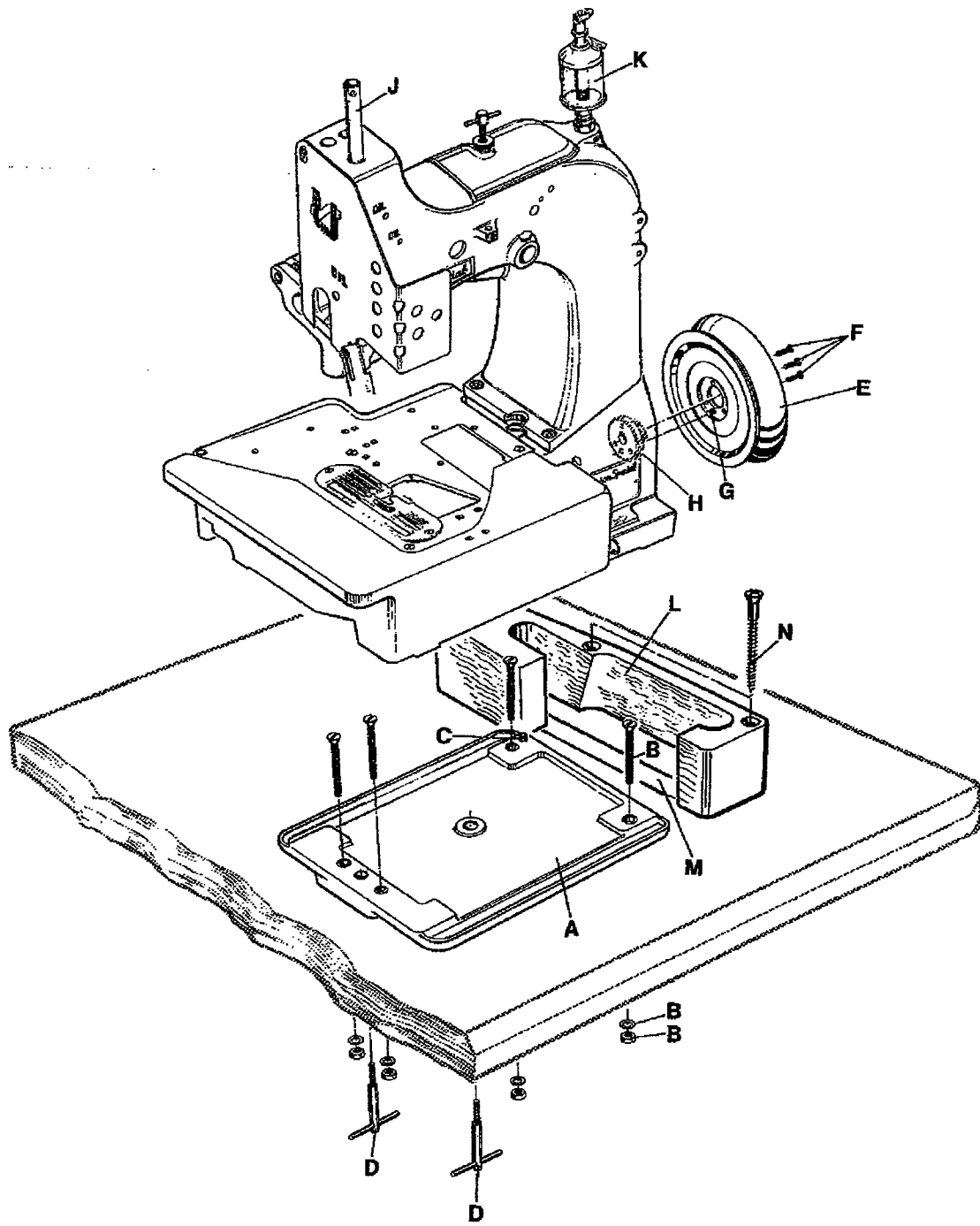

**Fig 6**

## **INSTALLATION** (continued)

1. Unpack the sewing machine and the accessories.
2. Mount the base plate (A, Fig. 6) with four screws, nuts and washers (B) in the provided holes on the table board.
3. Place the sewing machine on the base plate so that the roll pin (C) in the base plate engages with the right rear hole in the machine base.
4. Fasten the sewing machine with the two T-screws (D) on the base plate.
5. Place the V-belt, supplied with the sewing table, on the handwheel pulley.
6. Assemble the handwheel pulley (E) with three countersunk screws (F) to the sewing machine. Pin (G) must engage with the hole in hub (H).
7. Screw in needle bar guard (J).
8. Screw in sight feed roller (K).
9. Align the handwheel belt guard (L) with the V-belt slot (M) in the table board and with the handwheel pulley and fasten it with two wood screws (N) on the table board.
10. Dismount motor belt guard. Place the V-belt around the motor pulley and stue the motor to tense the belt. The tension on the V-belt is correct, when with moderate finger pressure it will deflect approx. 10 mm (3/8") midway between handwheel pulley on the sewing machine and motor pulley (see Fig. 7). Remount motor belt guard.

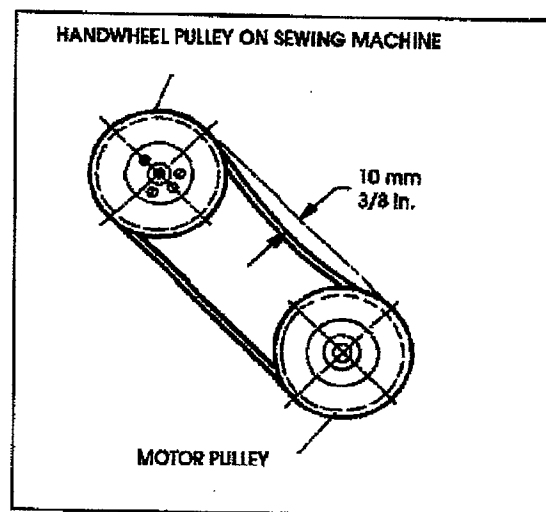

**Fig 7**

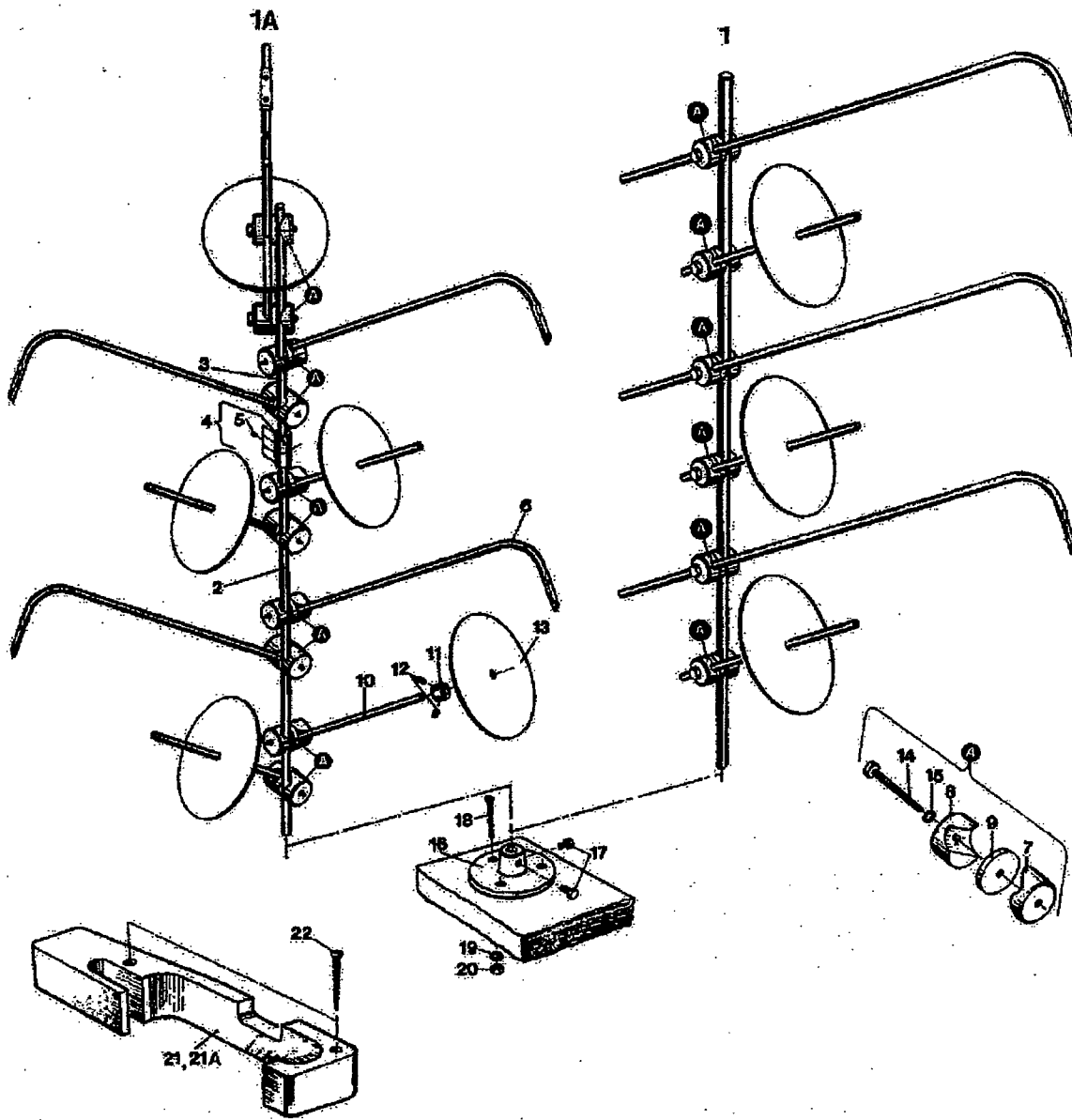



ACCESSORIES

<u>Ref. No.</u>	<u>Part No.</u>	<u>Description</u>	<u>Amf. Req.</u>
1	93065B3	Thread Stand, 3 Cones	1
1A	93065B5	Thread Stand, 5 Cones	1
2	93065BCB	Thread Stand Rod	1
3	93065BCA	Thread Stand Rod	1
4	93065BM	Coupling	1
5	99265	Set Screw	1
6	93065BE	Thread Guide	3/5
7	93065BG	Clamp Washer for 16 mm	6/10
8	93065BJ	Clamp Washer for 12 mm	6/10
9	93065BL	Washer	6/10
10	93065BD	Spool Pin	3/5
11	G41041B	Collar	3/5
12	531	Set Screw	6/10
13	90805K	Spool Seat Disc	3/5
14	95068A	Hex. Head Cap Screw	6/10
15	96201	Locking Ring	6/10
16	93065BA	Base:	1
17	95003	Hex. Head Cap Screw	2
18	95141A	Countersunk Screw	3
19	96902	Washer	3
20	95250	Hex. Nut	3
21	99681J	Belt Guard for handwheel	1
21A	99681JA	Belt Guard for handwheel with synchronizer	1
22	90562D	Countersunk Wood Screw	1







**JUKI**  
*Union Special*